

# Introduction to Finite Element Method (1993~2022)

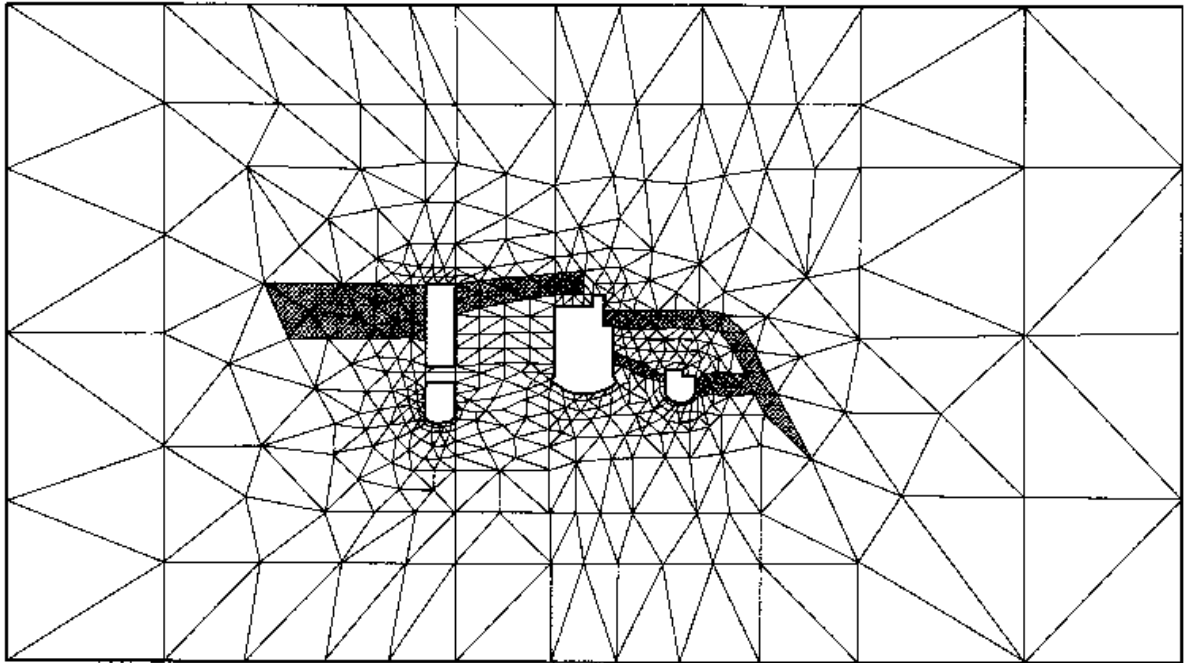

Fall Semester, 2022  
(Last Class at SNU)

Hae Sung Lee

Dept. of Civil and Environmental Engineering  
Seoul National University

# Contents

1. Introduction
2. Approximation of Functions & Variational Calculus
3. Differential Equations in One Dimension
4. Multi-dimensional Problems-Elasticity
5. Discretization
6. Two Dimensional Elasticity Problems
7. Various Types of Elements
8. Numerical Integration
9. Convergence Criteria in Isoparametric Element
10. Miscellaneous Topics
11. Problems with Higher Continuity Requirement - Beams
12. Mixed Formulation

# Chapter 2

## Approximation of Functions and Variational Calculus

$$\approx \delta$$

$\delta \alpha_k = \int_0^1 \left( \frac{\partial F}{\partial f} - \frac{d}{dx} \frac{\partial F}{\partial f'} \right) \delta f_k dx = 0$  for all  $k \Leftrightarrow \frac{\partial F}{\partial f} - \frac{d}{dx} \frac{\partial F}{\partial f'} = 0$

...functions vanish at the boundary...

$$\delta \Pi(f) = \int_0^1 \delta F(f, f', x) dx = \int_0^1 \left( \frac{\partial F}{\partial f} \delta f + \frac{\partial F}{\partial f'} \delta f' \right) dx = \int_0^1 \left( \frac{\partial F}{\partial f} \delta f + \frac{\partial F}{\partial f'} \delta f' \right) dx$$

$$= \frac{\partial F}{\partial f'} \delta f \Big|_0^1 + \int_0^1 \left( \frac{\partial F}{\partial f} \delta f - \frac{d}{dx} \frac{\partial F}{\partial f'} \delta f \right) dx$$

In case the variation vanishes at the boundaries, then

$$\delta \Pi = \int_0^1 \left( \frac{\partial F}{\partial f} - \frac{d}{dx} \frac{\partial F}{\partial f'} \right) \delta f dx = \int_0^1 \left( \frac{\partial F}{\partial f} - \frac{d}{dx} \frac{\partial F}{\partial f'} \right) \delta f dx = \delta \Pi$$

## Fundamental Considerations

- **What is the best solution for a given problem ?**

Needless to say, it is the exact solution...

- **What is the exact solution?**

The solution that satisfies the governing equations as well as boundary conditions if any.

- **How many do the exact solutions exist?**

Of course, one... In case several or infinite numbers of the exact solutions exist for a given equation, we call the problem as an ill-posed problem, and have great difficulties in determining a solution of the given problem...

- **What if it is impossible to determine the exact solution for various reasons?**

We need approximate solution.

- **What is an approximate solution?**

- **Fundamental Questions**

- What is the best approximation?
- How can we mathematically represent the best approximation?

- **A Good (or Robust or Well Formulated) Approximation Should**

- Yield the best approximation to the exact solution for a given degree of approximation.
- Converge to the exact solution as higher degree of approximation is employed.

- **What is the Definition of the Best Approximation?**

- May be defined as the closest solution to the exact solution.
- But, how close is "the closest"?
- "Close or Far" implies the distance between two spatial points.
- We should define some sort of ruler to measure the distance between two elements in a function set...

- **Norms of Functions:** A measure of a function set

A function set  $\mathcal{V}$  is said to be a *normed space* if to every  $f \in \mathcal{V}$  there associated a nonnegative real number  $\|f\|$ , called the norm of  $f$ , in a such way that

- $\|f\| = 0$  if and only if  $f \equiv 0$
- $\|\alpha f\| = |\alpha| \|f\|$  for any real number  $\alpha$ .
- $\|f + g\| \leq \|f\| + \|g\|$

Every normed space may be regarded as a metric space, in which the distance between any two elements in the space is measured by the defined norm. Various types of norm can be defined for a function space. Among them the following norms are important.

- $L_1$  norm:  $\|f\|_{L_1} = \int_{\mathcal{V}} |f| dV$
- $L_2$  norm:  $\|f\|_{L_2} = (\int_{\mathcal{V}} f^2 dV)^{1/2}$
- $H^1$  norm:  $\|f\|_{H^1} = (\int_{\mathcal{V}} (f^2 + \nabla f \cdot \nabla f) dV)^{1/2}$

- **Discretization**

- Representation of a continuously distributed quantities with some numbers.

$$f(\mathbf{X}) = \sum_{i=1}^n a_i g_i(\mathbf{X}) \quad \forall f(\mathbf{X}) \in \mathcal{V} \quad \text{where } g_i \text{ are the basis functions of a function set, } \mathcal{V}$$

- Set : Collection of some objectives with the same characteristics
- The basis functions should be linearly independent to each other.

$$\sum_{i=1}^n a_i g_i(\mathbf{X}) = 0 \quad \text{if and only if all } a_i = 0$$

- Taylor series, Fourier series, etc...

- **Approximations - Truncation**

$$f(\mathbf{X}) = \sum_{i=1}^n a_i g_i(\mathbf{X}) \approx f^h(\mathbf{X}) = \sum_{i=1}^m a_i g_i(\mathbf{X}) \in \mathcal{V}^h \subset \mathcal{V} \quad \text{where } m \leq n$$

- **Summation Notation:** Repeated indices denote summation  $\sum_{i=1}^m a_i b_i = a_i b_i$ .

- **General Ideas for the Best Approximation**

Let's find out a approximate function that is closest to the given function by use of a norm defined in the function space. If this is the case, the characteristics of an approximation method depend on those of the norm used in the approximation.

- **Least Square Error(LSE) Minimization**

$$\text{Error: } e = f - f^h$$

$$\text{Minimize } \Pi = \frac{1}{2} \|e\|_{L_2}^2 = \frac{1}{2} \|f - f^h\|_{L_2}^2 = \frac{1}{2} \int_V (f - f^h)^2 dV$$

$$\frac{\partial \Pi}{\partial a_k} = \int_V (f^h - f) \frac{\partial f^h}{\partial a_k} dV = \int_V (f^h - f) g_k dV$$

$$= \int_V g_k \sum_{i=1}^m g_i a_i dV - \int_V g_k f dV$$

$$= \sum_{i=1}^m \int_V g_k g_i dV a_i - \int_V g_k f dV = \sum_{i=1}^m K_{ki} a_i - F_k = 0 \text{ for } k = 1, \dots, m$$

Final System Equation :  $\mathbf{K}\mathbf{a} = \mathbf{F}$

If the basis functions are orthogonal,  $\mathbf{K}$  becomes diagonal.

- **Variation of a function**

- The variation of a function means a possible change in the function for the fixed  $x$ .

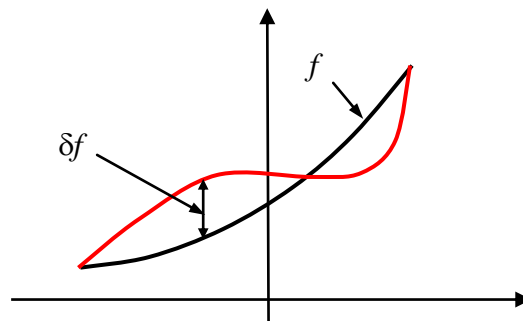

Variation of a function

- **Variational Calculus**

- if  $f = a_i g_i$  then

the variation of  $f$  is defined as  $\delta f = \delta a_i g_i$  or by definition  $\delta f = \frac{\partial f}{\partial a_i} \delta a_i$ .

-  $F(f) : \delta F = \frac{\partial F}{\partial a_i} \delta a_i = \frac{\partial F}{\partial f} \frac{\partial f}{\partial a_i} \delta a_i = \frac{\partial F}{\partial f} \delta f$

-  $\delta(f + h) = \delta f + \delta h$

- $\delta(fh) = h\delta f + f\delta h$
- $\delta \frac{df}{dx} = \frac{\partial}{\partial a_i} \left( \frac{df}{dx} \right) \delta a_i = \frac{d}{dx} \left( \frac{\partial f}{\partial a_i} \delta a_i \right) = \frac{d\delta f}{dx}$ ,
- $\delta \int f dx = \frac{\partial}{\partial a_i} \int f dx \delta a_i = \int \frac{\partial f}{\partial a_i} \delta a_i dx = \int \delta f dx$

- **Minimization by Variational Calculus**

$$\text{Min } \Pi(f^h) = \frac{1}{2} \int_0^l (f - f^h)^2 dx$$

$$\begin{aligned} \delta \Pi(f^h) &= \delta \left( \frac{1}{2} \int_0^l (f^h - f)^2 dx \right) = \frac{1}{2} \int_0^l \delta (f^h - f)^2 dx = \int_0^l (f^h - f) \delta f^h dx \\ &= \int_0^l (f^h - f) \frac{\partial f^h}{\partial a_k} dx \delta a_k = \frac{\partial \Pi}{\partial a_k} \delta a_k \end{aligned}$$

$$\text{Min } \Pi(f^h) = \frac{1}{2} \int_V (f - f^h)^2 dV \Leftrightarrow \delta \Pi = 0 \text{ for all possible } \delta a_k$$

- **Euler Equation**

$$\text{Min } \Pi(f) = \int_0^l F(f, f', x) dx \Rightarrow \frac{\partial \Pi}{\partial a_k} = 0 \text{ for all } k$$

$$\begin{aligned} \frac{\partial \Pi}{\partial a_k} &= \frac{\partial}{\partial a_k} \int_0^l F(f, f', x) dx = \int_0^l \frac{\partial F}{\partial a_k} dx = \int_0^l \left( \frac{\partial F}{\partial f} \frac{\partial f}{\partial a_k} + \frac{\partial F}{\partial f'} \frac{\partial f'}{\partial a_k} \right) dx = \int_0^l \left( \frac{\partial F}{\partial f} g_k + \frac{\partial F}{\partial f'} g'_k \right) dx \\ &= \frac{\partial F}{\partial f'} g_k \Big|_0^l + \int_0^l \left( \frac{\partial F}{\partial f} g_k - \frac{d}{dx} \frac{\partial F}{\partial f'} g_k \right) dx \end{aligned}$$

In case the **basis functions vanish** at the boundary, then

$$\frac{\partial \Pi}{\partial a_k} = \int_0^l \left( \frac{\partial F}{\partial f} - \frac{d}{dx} \frac{\partial F}{\partial f'} \right) g_k dx = 0 \text{ for all } k \Leftrightarrow \frac{\partial F}{\partial f} - \frac{d}{dx} \frac{\partial F}{\partial f'} = 0$$

$$\delta \Pi(f) = \int_0^l \delta F(f, f', x) dx = \int_0^l \left( \frac{\partial F}{\partial f} \delta f + \frac{\partial F}{\partial f'} \delta f' \right) dx = \frac{\partial F}{\partial f'} \delta f \Big|_0^l + \int_0^l \left( \frac{\partial F}{\partial f} \delta f - \frac{d}{dx} \frac{\partial F}{\partial f'} \delta f \right) dx$$

In case the variation vanishes at the boundaries, then

$$\delta \Pi(f) = \int_0^l \left( \frac{\partial F}{\partial f} - \frac{d}{dx} \frac{\partial F}{\partial f'} \right) \delta f dx = \int_0^l \left( \frac{\partial F}{\partial f} - \frac{d}{dx} \frac{\partial F}{\partial f'} \right) g_k dx \delta a_k = \frac{\partial \Pi}{\partial a_k} \delta a_k.$$

Therefore,

$$\text{Min } \Pi \Leftrightarrow \delta \Pi = 0$$

- **Example 1**

$$\text{Min } \Pi(y) = \int_{x_1}^{x_2} \sqrt{1+(y')^2} dx \quad \text{subject to } y(x_1) = y_1, \quad y(x_2) = y_2$$

$$\frac{\partial F}{\partial f} - \frac{d}{dx} \frac{\partial F}{\partial f'} = 0 - \frac{d}{dx} \left( \frac{\partial}{\partial y'} \sqrt{1+(y')^2} \right) = -\frac{d}{dx} y'(1+(y')^2)^{-1/2} = 0$$

$$\begin{aligned} \frac{d}{dx} y'(1+(y')^2)^{-1/2} &= y''(1+(y')^2)^{-1/2} + y' \left( -\frac{1}{2} \right) (1+(y')^2)^{-3/2} y' y'' \\ &= y''(1+(y')^2)^{-1/2} \left( 1 - \frac{(y')^2}{1+(y')^2} \right) = y''(1+(y')^2)^{-3/2} = 0 \end{aligned}$$

$$y'' = 0 \rightarrow y = ax + b. \quad \text{By applying BC, } y'' = 0 \rightarrow y = \frac{y_2 - y_1}{x_2 - x_1} x + \frac{x_2 y_1 - x_1 y_2}{x_2 - x_1}$$

- **Example 2**

$$\text{Min } \Pi(u) = \int_0^l \left( \frac{1}{2} (u')^2 - uf \right) dx \quad \text{subject to } u(0) = 0, \quad u(l) = 0$$

$$\frac{\partial F}{\partial u} - \frac{d}{dx} \frac{\partial F}{\partial u'} = -f - \frac{d}{dx} \left( \frac{\partial}{\partial u'} \frac{1}{2} (u')^2 \right) = -f - \frac{d}{dx} u' = -f - u'' = 0 \rightarrow u'' + f = 0$$

- **Homework 1**

1. Approximate a cosine function  $y = \cos \frac{2\pi}{l} x$  by polynomials based the minimization of the least square errors. Use polynomials up to the 20<sup>th</sup> order. You may use a numerical integration algorithm such as Simpson's rule, the trapezoidal rule or the rectangular rule. You also need a numerical solver to solve linear simultaneous equations in the "Linpack". For the accuracy of your calculation, please use "double precision" in your program. You should present proper discussions on your results together with some graphs that show your approximate functions and the given function.

2. Derive Euler equation for the following minimization function, and proper boundary conditions.

$$\text{Min } \Pi(f) = \int_0^l F(f, f', f'', x) dx$$

3. Derive the governing equation and the boundary conditions for the following problem.

$$\text{Min } \Pi(w) = \int_0^l \left( \frac{1}{2} \left( \frac{d^2 w}{dx^2} \right)^2 - wq \right) dx$$



# Chapter 3

## Elliptic Differential Equations in One Dimension

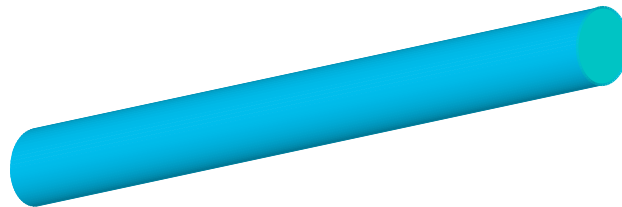

$$\begin{aligned}
 \int_{x_0}^{x_1} \left( \frac{d}{dx} \left( \frac{d}{dx} U \right) \right) dx &= \\
 &= \delta U_1 \int_{x_1}^{x_2} \left( \frac{d}{dx} \left( \frac{d}{dx} U_1 \right) \right) dx \\
 &+ \delta U_2 \int_{x_2}^{x_3} \left( \frac{d}{dx} \left( \frac{d}{dx} U_2 \right) + \frac{d}{dx} \right) dx \\
 &\dots \\
 &+ \delta U_{i-1} \int_{x_{i-1}}^{x_i} \left( \frac{d}{dx} \left( \frac{d}{dx} U_{i-1} \right) + \frac{d}{dx} \right) dx \\
 &+ \delta U_i \int_{x_i}^{x_{i+1}} \left( \frac{d}{dx} \left( \frac{d}{dx} U_i \right) + \frac{d}{dx} \right) dx \\
 &+ \delta U_{i+1} \int_{x_{i+1}}^{x_{i+2}} \left( \frac{d}{dx} \left( \frac{d}{dx} U_{i+1} \right) \right) dx \\
 &\dots \\
 &+ \delta U_{i-1} \int_{x_{i-1}}^{x_i} \left( \frac{d}{dx} \left( \frac{d}{dx} U_{i-1} \right) \right) dx
 \end{aligned}$$

### 3.1. Problems with homogenous displacement boundary conditions

- **Problem Definition**

$$\frac{d^2u}{dx^2} + f = 0 \quad 0 < x < l, \quad u(0) = u(l) = 0$$

- **Approximation – Discretization**

$$u^h = \sum_{i=1}^m a_i g_i \quad \text{where} \quad u^h(0) = u^h(l) = 0$$

- **Residuals**

Verbal Definition : Something left over, or resulting from subtraction...

Equation Residual :  $R_E = \frac{d^2u^h}{dx^2} + f \neq 0 \quad 0 < x < l$

Function Residual :  $R_F = u - u^h \neq 0 \quad 0 < x < l$

- **Error Estimator :**

$$\Pi^R = \frac{1}{2} \int_0^l R_F R_E dx = \frac{1}{2} \int_0^l (u - u^h) \left( \frac{d^2u^h}{dx^2} + f \right) dx$$

- **Least Square Error**

$$\begin{aligned} \Pi^R &= \frac{1}{2} \int_0^l (u - u^h) \left( \frac{d^2u^h}{dx^2} + f \right) dx \\ &= \frac{1}{2} \int_0^l (u - u^h) \left( \frac{d^2u^h}{dx^2} - \frac{d^2u}{dx^2} \right) dx \\ &= \frac{1}{2} (u - u^h) \left( \frac{du^h}{dx} - \frac{du}{dx} \right) \Big|_0^l - \frac{1}{2} \int_0^l \left( \frac{du}{dx} - \frac{du^h}{dx} \right) \left( \frac{du^h}{dx} - \frac{du}{dx} \right) dx \\ &= \frac{1}{2} \int_0^l \left( \frac{du}{dx} - \frac{du^h}{dx} \right) \left( \frac{du}{dx} - \frac{du^h}{dx} \right) dx = \Pi^{LS} \leftarrow \text{Least Square Error} \end{aligned}$$

- **Energy Functional – Total Potential Energy**

$$\begin{aligned} \Pi^R &= \frac{1}{2} \int_0^l (u - u^h) \left( \frac{d^2u^h}{dx^2} + f \right) dx = \frac{1}{2} \int_0^l \left( u \frac{d^2u^h}{dx^2} + uf - u^h \frac{d^2u^h}{dx^2} - u^h f \right) dx \\ &= \frac{1}{2} \left\{ \int_0^l (uf - u^h f) dx + u \frac{du^h}{dx} \Big|_0^l - \frac{du}{dx} u^h \Big|_0^l + \int_0^l \frac{d^2u}{dx^2} u^h dx - u^h \frac{du^h}{dx} \Big|_0^l + \int_0^l \frac{du^h}{dx} \frac{du^h}{dx} dx \right\} \\ &= \frac{1}{2} \int_0^l uf dx + \left( \frac{1}{2} \int_0^l \frac{du^h}{dx} \frac{du^h}{dx} dx - \int_0^l u^h f dx \right) = C + \Pi^{RR} \quad \leftarrow -f \end{aligned}$$

- **Minimization Problems**

$$\text{Min } \Pi^R \Leftrightarrow \text{Min } \Pi^{LS} \Leftrightarrow \text{Min } \Pi^{RR} \text{ w.r.t. } u^h \in \mathfrak{U}^h$$

- $\text{Min } \Pi^{RR}$  : **Rayleigh-Ritz Method** or **Principle of Minimum Potential Energy**

-  $1^{st}$  Order Necessary Condition for Minimization Problem

$$\begin{aligned} \frac{\partial \Pi^{RR}}{\partial a_k} &= \int_0^l \frac{d}{da_k} \left( \frac{du^h}{dx} \right) \frac{du^h}{dx} dx - \int_0^l \frac{du^h}{da_k} f dx \\ &= \int_0^l \frac{d}{da_k} \left( \sum_{i=1}^m a_i \frac{\partial g_i}{\partial x} \right) \left( \sum_{i=1}^m a_i \frac{\partial g_i}{\partial x} \right) dx - \int_0^l \frac{d}{da_k} \left( \sum_{i=1}^m a_i g_i \right) f dx \\ &= \sum_{i=1}^m \int_0^l \frac{dg_k}{dx} \frac{dg_i}{dx} dx a_i - \int_0^l g_k f dx \\ &= \sum_{i=1}^m K_{ki} a_i - F_k = 0 \text{ for } k=1, \dots, m \rightarrow \mathbf{K}\mathbf{a} = \mathbf{F} \end{aligned}$$

- $\delta \Pi^{RR} = 0$  : **Variational principle** or **Principle of Virtual Work**

$$\begin{aligned} \delta \Pi^{RR} &= \delta \left( \frac{1}{2} \int_0^l \frac{du^h}{dx} \frac{du^h}{dx} dx - \int_0^l u^h f dx \right) \\ &= \int_0^l \frac{du^h}{dx} \delta \frac{du^h}{dx} dx - \int_0^l \delta u^h f dx = \int_0^l \frac{d\delta u^h}{dx} \frac{du^h}{dx} dx - \int_0^l \delta u^h f dx \\ &= \sum_{k=1}^m \delta a_k \left( \sum_{i=1}^m \int_0^l \frac{dg_k}{dx} \frac{dg_i}{dx} dx a_i - \int_0^l g_k f dx \right) \\ &= \sum_{k=1}^m \delta a_k \left( \sum_{i=1}^m K_{ki} a_i - F_k \right) = 0 \rightarrow (\delta \mathbf{a})^T (\mathbf{K}\mathbf{a} - \mathbf{F}) = 0 \end{aligned}$$

- **Solution Space**

-  $u \in \mathfrak{U} \equiv \{u \mid u(0) = u(l) = 0, \int_0^l \left( \frac{du}{dx} \right)^2 dx < \infty\}$

-  $\mathfrak{U}^h \equiv \mathfrak{U}$  : The minimization problems yield the exact solution.

-  $\mathfrak{U}^h \subset \mathfrak{U}$  : The minimization problems yield an approximate solution.

- **Properties of K**

- **Symmetry** :  $K_{ij} = \int_0^l \frac{dg_i}{dx} \frac{dg_j}{dx} dx = \int_0^l \frac{dg_j}{dx} \frac{dg_i}{dx} dx = K_{ji}$

- **Positive Definiteness** :

$$\begin{aligned} \int_0^l \left( \frac{du^h}{dx} \right)^2 dx &= \int_0^l \sum_{i=1}^m \frac{dg_i}{dx} a_i \sum_{j=1}^m \frac{dg_j}{dx} a_j dx \\ &= \sum_{i=1}^m a_i \sum_{j=1}^m \int_0^l \frac{dg_i}{dx} \frac{dg_j}{dx} dx a_j = \sum_{i=1}^m \sum_{j=1}^m a_i K_{ij} a_j = \mathbf{a}^T \mathbf{K} \mathbf{a} \geq 0 \end{aligned}$$

- **Absolute Minimum Property of Total Potential Energy**

$$u^h = u - u^e$$

$$\begin{aligned} \Pi^h &= \frac{1}{2} \int_0^l \frac{du^h}{dx} \frac{du^h}{dx} dx - \int_0^l u^h f dx = \frac{1}{2} \int_0^l \frac{d(u - u^e)}{dx} \frac{d(u - u^e)}{dx} dx - \int_0^l (u - u^e) f dx \\ &= \frac{1}{2} \int_0^l \frac{du}{dx} \frac{du}{dx} dx - \int_0^l u f dx + \frac{1}{2} \int_0^l \frac{du^e}{dx} \frac{du^e}{dx} dx - \int_0^l \frac{du^e}{dx} \frac{du}{dx} dx + \int_0^l u^e f dx \\ &= \frac{1}{2} \int_0^l \frac{du}{dx} \frac{du}{dx} dx - \int_0^l u f dx + \frac{1}{2} \int_0^l \frac{du^e}{dx} \frac{du^e}{dx} dx - u^e \frac{du}{dx} \Big|_0^l + \int_0^l u^e \frac{d^2 u}{dx^2} dx + \int_0^l u^e f dx \\ &= \frac{1}{2} \int_0^l \frac{du}{dx} \frac{du}{dx} dx - \int_0^l u f dx + \frac{1}{2} \int_0^l \frac{du^e}{dx} \frac{du^e}{dx} dx + \int_0^l u^e \left( \frac{d^2 u}{dx^2} + f \right) dx \\ &= \frac{1}{2} \int_0^l \frac{du}{dx} \frac{du}{dx} dx - \int_0^l u f dx + \frac{1}{2} \int_0^l \frac{du^e}{dx} \frac{du^e}{dx} dx \\ &= \Pi^E + \frac{1}{2} \int_0^l \left( \frac{du^e}{dx} \right)^2 dx \geq \Pi^E \quad (\text{The equality sign holds only for } u^e = C) \end{aligned}$$

- **Weighted Residual Method**

$$\pi_k = \int_0^l \phi_k R_E dx = \int_0^l \phi_k \left( \frac{d^2 u^h}{dx^2} + f \right) dx = 0 \quad \text{for } k = 1, \dots, m$$

- if  $\phi_k = g_k$  : Galerkin Method (elliptic System or self-adjoint system)

$$\begin{aligned} \pi_k &= \int_0^l \phi_k \left( \frac{d^2 u^h}{dx^2} + f \right) dx = g_k \frac{du^h}{dx} \Big|_0^l - \int_0^l \frac{dg_k}{dx} \frac{du^h}{dx} dx + \int_0^l g_k f dx \\ &= - \int_0^l \frac{dg_k}{dx} \frac{du^h}{dx} dx + \int_0^l g_k f dx = - \int_0^l \frac{dg_k}{dx} \sum_{i=1}^{m'} \frac{dg_i}{dx} a_i dx + \int_0^l g_k f dx \\ &= - \sum_{i=1}^{m'} \int_0^l \frac{dg_k}{dx} \frac{dg_i}{dx} dx a_i + \int_0^l g_k f dx = 0 \quad \text{for } k = 1, \dots, m \rightarrow \mathbf{Ka} = \mathbf{F} \end{aligned}$$

- **Identical result to the Rayleigh-Ritz Method or Variational Principle**

- if  $\phi_k \neq g_k$  : Petrov-Galerkin Method (hyperbolic system or non-self adjoint system)

- **Weighted Residual Method vs. Variational Principle**

$$\pi_k = 0 \quad \text{for } k = 1, \dots, m \Leftrightarrow \sum_{i=1}^m \pi_i \delta a_i = 0 \quad \forall \delta a_i$$

$$\begin{aligned} \sum_{i=1}^m \pi_i \delta a_i &= \sum_{i=1}^m \delta a_i \int_0^l g_i \left( \frac{d^2 u^h}{dx^2} + f \right) dx = \int_0^l \sum_{i=1}^m \delta a_i g_i \left( \frac{d^2 u^h}{dx^2} + f \right) dx = \\ \int_0^l \delta u^h \left( \frac{d^2 u^h}{dx^2} + f \right) dx &= - \left( \int_0^l \frac{d\delta u^h}{dx} \frac{du^h}{dx} dx - \int_0^l \delta u^h f dx \right) = 0 \quad \text{for all possible } \delta u^h \end{aligned}$$

- **Example 1 :**  $\frac{d^2u}{dx^2} = -1$ ,  $u(0) = u(1) = 0$

- Exact solution :  $u = -\frac{1}{2}x^2 + \frac{1}{2}x$

- First trial :  $u^h = a_1 + a_2x + a_3x^2$

Applying BCs :  $a_1 = 0$ ,  $a_2 = -a_3 \rightarrow u^h = a_3(-x + x^2)$ ,  $\frac{du^h}{dx} = a_3(-1 + 2x)$

$$K_{11} = \int_0^1 (-1 + 2x)^2 dx = \frac{1}{3}, \quad F_1 = \int_0^1 1 \cdot (-x + x^2) dx = -\frac{1}{6}$$

$$\frac{1}{3}a_3 = -\frac{1}{6} \rightarrow a_3 = -\frac{1}{2}. \quad \text{Therefore, } u^h \equiv u$$

- Second Trial :  $u^h = a_1 + a_2x + a_3x^2 + a_4x^3$

Applying BCs :  $a_1 = 0$ ,  $a_2 = -a_3 - a_4 \rightarrow u^h = a_3 \underbrace{(-x + x^2)}_{g_1} + a_4 \underbrace{(-x + x^3)}_{g_2}$

$$\frac{dg_1}{dx} = (-1 + 2x), \quad \frac{dg_2}{dx} = (-1 + 3x^2)$$

$$K_{11} = \int_0^1 (-1 + 2x)^2 dx = \frac{1}{3}, \quad K_{22} = \int_0^1 (-1 + 3x^2)^2 dx = \frac{4}{5}$$

$$K_{12} = K_{21} = \int_0^1 (-1 + 2x)(-1 + 3x^2) dx = \frac{1}{2}$$

$$F_1 = \int_0^1 1 \cdot (-x + x^2) dx = -\frac{1}{6}, \quad F_2 = \int_0^1 1 \cdot (-x + x^3) dx = -\frac{1}{4}$$

System Equation :  $\begin{bmatrix} \frac{1}{3} & \frac{1}{2} \\ \frac{1}{2} & \frac{4}{5} \end{bmatrix} \begin{Bmatrix} a_3 \\ a_4 \end{Bmatrix} = \begin{Bmatrix} -\frac{1}{6} \\ -\frac{1}{4} \end{Bmatrix} \rightarrow a_3 = -\frac{1}{2}, a_4 = 0$

- **Example 2 :**  $\frac{d^2u}{dx^2} = -\pi^2 \sin \pi x$ ,  $u(0) = u(1) = 0$

- Exact Solution :  $u = \sin \pi x$

- First trial :  $u^h = a_1 + a_2x + a_3x^2$

Applying BCs :  $u^h = a_2(-x + x^2)$ ,  $\frac{du^h}{dx} = a_2(-1 + 2x)$

$$K_{11} = \int_0^1 (-1 + 2x)^2 dx = \frac{1}{3}, \quad F_1 = \pi^2 \int_0^1 \sin \pi x \cdot (-x + x^2) dx = -\frac{4}{\pi}$$

$$\frac{1}{3}a_2 = -\frac{4}{\pi} \rightarrow a_2 = -\frac{12}{\pi}. \quad \text{Therefore, } u^h = -\frac{12}{\pi}(-x + x^2)$$

$$u^h(0.5) = \frac{3}{\pi} = 0.955 \quad \text{Error} = 4.5 \%$$

- Second trial :  $u^h = a_0 + a_1x + a_2x^2 + a_3x^3$

$$\text{Applying BCs : } a_1 = 0, \quad a_2 = -a_3 - a_4 \rightarrow u^h = a_3 \underbrace{(-x + x^2)}_{g_1} + a_4 \underbrace{(-x + x^3)}_{g_2}$$

$$\frac{dg_1}{dx} = (-1 + 2x), \quad \frac{dg_2}{dx} = (-1 + 3x^2)$$

$$K_{11} = \int_0^1 (-1 + 2x)^2 dx = \frac{1}{3}, \quad K_{22} = \int_0^1 (-1 + 3x^2)^2 dx = \frac{4}{5}$$

$$K_{12} = K_{21} = \int_0^1 (-1 + 2x)(-1 + 3x^2) dx = \frac{1}{2}$$

$$F_1 = \pi^2 \int_0^1 \sin \pi x \cdot (-x + x^2) dx = -\frac{4}{\pi}, \quad F_2 = \pi^2 \int_0^1 \sin \pi x \cdot (-x + x^3) dx = -\frac{6}{\pi}$$

$$\text{System Equation : } \begin{bmatrix} \frac{1}{3} & \frac{1}{2} \\ \frac{1}{2} & \frac{4}{5} \end{bmatrix} \begin{Bmatrix} a_2 \\ a_3 \end{Bmatrix} = \begin{Bmatrix} -\frac{4}{\pi} \\ -\frac{6}{\pi} \end{Bmatrix} \rightarrow a_2 = -\frac{12}{\pi}, a_3 = 0 \quad \text{????}$$

- In general  $u^h = \sum_{i=2}^{m'} a_i (-x + x^i)$

$$\text{Function Error} = \left( \frac{\int_0^1 (\sin \pi x - u^h)^2 dx}{\int_0^1 \sin^2 \pi x dx} \right)^{1/2}$$

$$\text{Derivative Error} = \left( \frac{\int_0^1 (\pi \cos \pi x - (u^h)')^2 dx}{\pi^2 \int_0^1 \cos^2 \pi x dx} \right)^{1/2}$$

To evaluate numerator in the error expressions, the midpoint rule with 100 subintervals is employed.

- Raw Output

```
***** 2th-order Polynomial *****
a 2 = -0.3819719E+01
Errors for 2th-order polynomial
Function error = 0.2009211E+01 %
Derivative error = 0.6010036E+01 %

***** 3th-order Polynomial *****
```

```
a 2 = -0.3819719E+01
a 3 = 0.0000000E+00

Errors for 3th-order polynomial
  Function error = 0.2009211E+01 %
  Derivative error = 0.6010036E+01 %

***** 4th-order Polynomial *****

a 2 = 0.4193832E+00
a 3 = -0.7065170E+01
a 4 = 0.3532585E+01

Errors for 4th-order polynomial
  Function error = 0.4048880E-01 %
  Derivative error = 0.1956108E+00 %

***** 5th-order Polynomial *****

a 2 = 0.4193832E+00
a 3 = -0.7065170E+01
a 4 = 0.3532585E+01
a 5 = 0.7833734E-12

Errors for 5th-order polynomial
  Function error = 0.4048880E-01 %
  Derivative error = 0.1956108E+00 %

***** 6th-order Polynomial *****

a 2 = -0.1405727E-01
a 3 = -0.5042448E+01
a 4 = -0.5128593E+00
a 5 = 0.3640900E+01
a 6 = -0.1213633E+01

Errors for 6th-order polynomial
  Function error = 0.4444114E-03 %
  Derivative error = 0.2944068E-02 %

***** 7th-order Polynomial *****

a 2 = -0.1405727E-01
a 3 = -0.5042448E+01
a 4 = -0.5128593E+00
a 5 = 0.3640900E+01
a 6 = -0.1213633E+01
a 7 = 0.5029577E-09

Errors for 7th-order polynomial
  Function error = 0.4444114E-03 %
  Derivative error = 0.2944068E-02 %

***** 8th-order Polynomial *****

a 2 = 0.2231430E-03
a 3 = -0.5170971E+01
a 4 = 0.2265606E-01
a 5 = 0.2462766E+01
a 6 = 0.2001274E+00
a 7 = -0.8751851E+00
a 8 = 0.2187963E+00

Errors for 8th-order polynomial
```

```
Function error = 0.3045376E-05 %  
Derivative error = 0.2548945E-04 %
```

```
***** 9th-order Polynomial *****
```

```
a 2 = 0.2231387E-03  
a 3 = -0.5170971E+01  
a 4 = 0.2265578E-01  
a 5 = 0.2462767E+01  
a 6 = 0.2001259E+00  
a 7 = -0.8751837E+00  
a 8 = 0.2187955E+00  
a 9 = 0.1698185E-06
```

```
Errors for 9th-order polynomial  
Function error = 0.3045376E-05 %  
Derivative error = 0.2548945E-04 %
```

```
***** 10th-order Polynomial *****
```

```
a 2 = -0.2313690E-05  
a 3 = -0.5167665E+01  
a 4 = -0.4905381E-03  
a 5 = 0.2553037E+01  
a 6 = -0.1050486E-01  
a 7 = -0.5742830E+00  
a 8 = -0.3911909E-01  
a 9 = 0.1217931E+00  
a10 = -0.2435856E-01
```

```
Errors for 10th-order polynomial  
Function error = 0.1289526E-07 %  
Derivative error = 0.1450501E-06 %
```

```
***** 11th-order Polynomial *****
```

```
a 2 = -0.4281311E-05  
a 3 = -0.5167629E+01  
a 4 = -0.7974500E-03  
a 5 = 0.2554541E+01  
a 6 = -0.1501611E-01  
a 7 = -0.5656904E+00  
a 8 = -0.4955267E-01  
a 9 = 0.1296181E+00  
a10 = -0.2766239E-01  
a11 = 0.6006860E-03
```

```
Errors for 11th-order polynomial  
Function error = 0.2263193E-07 %  
Derivative error = 0.2253144E-06 %
```



- Result plots

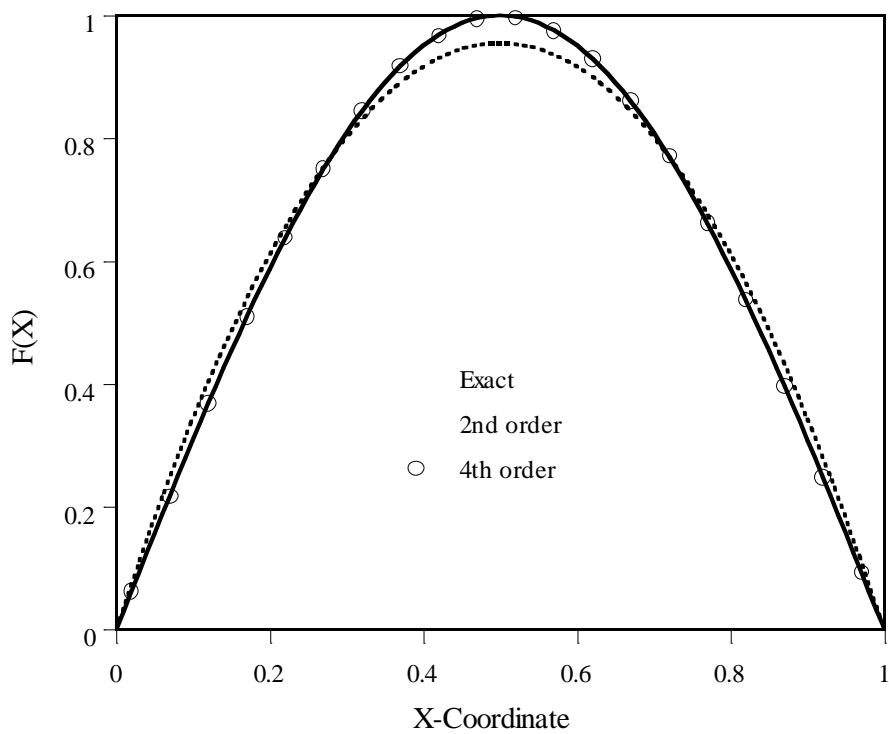
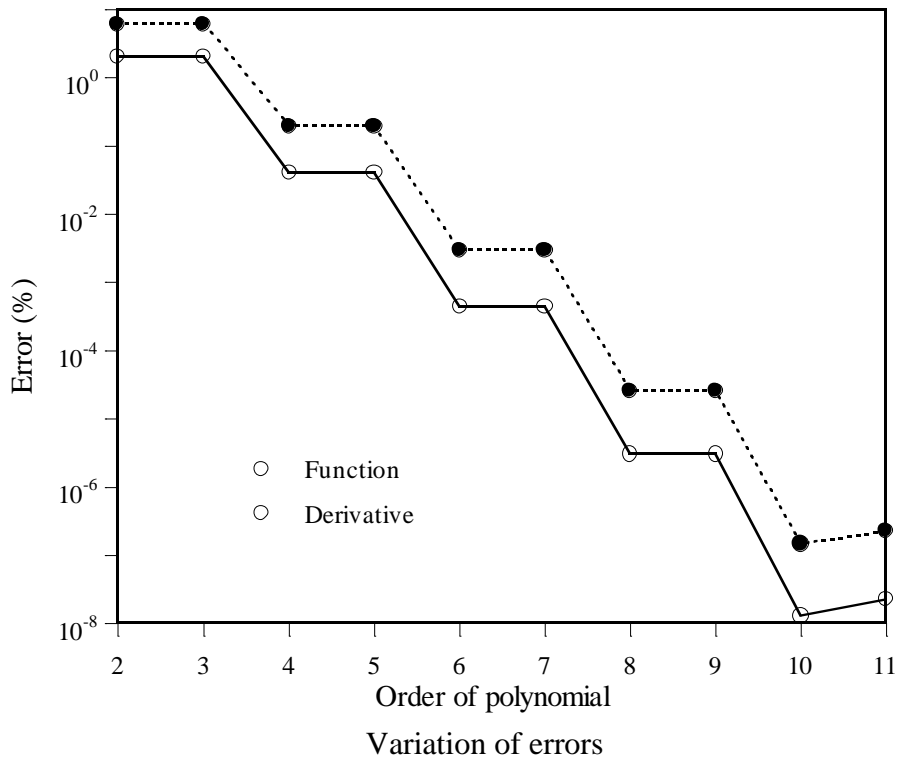

Plot of approximate function for different orders of polynomial

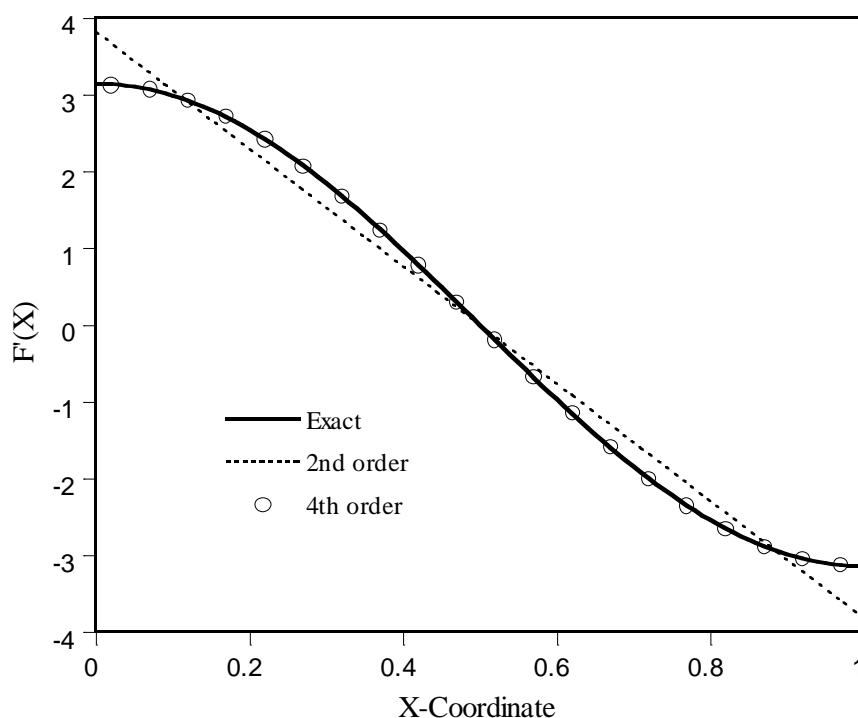

Plot of derivative approximate function for different orders of polynomial

## • Homework 2

1. Derive  $\Pi^{RR}$  for the following ODE for a beam subject to axial force  $P$  (positive for compression) as well as a traverse load  $q$ . Assume homogeneous displacement BCs.

$$EI \frac{d^4 w}{dx^4} + P \frac{d^2 w}{dx^2} - q = 0$$

2. On what condition does the principle of minimum potential energy hold for Prob. 1 ? Discuss the physical and the mathematical meanings of the condition.
3. Approximate solutions for a fixed-fixed end beam with a uniform load by polynomials with one unknown and two unknowns. No axial force is applied. Compare your solutions including displacement, rotation, moment and shear force to exact solution and discuss.

### 3.2. Problems with Traction Boundary Conditions

- **Problem Definition**

- Differential Equation

$$\frac{d^2 u}{dx^2} + f = 0 \quad 0 < x < l$$

- Boundary Conditions

$$\text{at } x=0 \quad u=0 \quad \text{or} \quad \frac{du}{dx} = \bar{T} \quad \text{and at } x=l \quad u=0 \quad \text{or} \quad \frac{du}{dx} = \bar{T}$$

- **Error Minimization: Error Estimator**

$$\begin{aligned} \Pi^R &= \frac{1}{2} \int_0^l (u - u^h) \left( \frac{d^2 u^h}{dx^2} + f \right) dx + \frac{1}{2} (u - u^h) \left( \frac{du}{dx} - \frac{du^h}{dx} \right) \Big|_0^l \\ &= \frac{1}{2} (u - u^h) \left( \frac{du^h}{dx} - \frac{du}{dx} \right) \Big|_0^l - \frac{1}{2} \int_0^l \left( \frac{du}{dx} - \frac{du^h}{dx} \right) \left( \frac{du^h}{dx} - \frac{du}{dx} \right) dx + \frac{1}{2} (u - u^h) \left( \frac{du}{dx} - \frac{du^h}{dx} \right) \Big|_0^l \\ &= \frac{1}{2} \int_0^l \left( \frac{du}{dx} - \frac{du^h}{dx} \right) \left( \frac{du}{dx} - \frac{du^h}{dx} \right) dx = \Pi^{LS} \end{aligned}$$

- **Energy Functional – Total Potential Energy**

$$\begin{aligned} \Pi^R &= \frac{1}{2} \int_0^l (u - u^h) \left( \frac{d^2 u^h}{dx^2} + f \right) dx + \frac{1}{2} (u - u^h) \left( \frac{du}{dx} - \frac{du^h}{dx} \right) \Big|_0^l \\ &= \frac{1}{2} \int_0^l \left( u \frac{d^2 u^h}{dx^2} + u f - u^h \frac{d^2 u^h}{dx^2} - u^h f \right) dx + \frac{1}{2} (u - u^h) \left( \frac{du}{dx} - \frac{du^h}{dx} \right) \Big|_0^l \\ &= \frac{1}{2} \int_0^l (u f - u^h f) dx + \frac{1}{2} \left\{ u \frac{du^h}{dx} \Big|_0^l - \frac{du}{dx} u^h \Big|_0^l + \int_0^l \frac{d^2 u}{dx^2} u^h dx - u^h \frac{du^h}{dx} \Big|_0^l + \int_0^l \frac{du^h}{dx} \frac{du^h}{dx} dx \right\} \\ &\quad + \frac{1}{2} \left( u \frac{du}{dx} - u \frac{du^h}{dx} - u^h \frac{du}{dx} + u^h \frac{du^h}{dx} \right) \Big|_0^l \\ &= \frac{1}{2} \left( \int_0^l u f dx + u \bar{T} \Big|_0^l \right) + \frac{1}{2} \int_0^l \frac{du^h}{dx} \frac{du^h}{dx} dx - \int_0^l u^h f dx - u^h \bar{T} \Big|_0^l \\ &= C + \Pi^{RR} \end{aligned}$$

- **Minimization Problems**

$$\text{Min } \Pi^R \Leftrightarrow \text{Min } \Pi^{LS} \Leftrightarrow \text{Min } \Pi^{RR} \quad \text{w.r.t. } u^h \in \mathcal{V}^h$$

- Min  $\Pi^{RR}$ : **Rayleigh-Ritz Method** or **Principle of Minimum Potential Energy**

- 1<sup>st</sup> Order Necessary Condition of Minimization Problem

$$\begin{aligned}\frac{\partial \Pi^{RR}}{\partial a_k} &= \int_0^l \frac{d}{da_k} \left( \frac{du^h}{dx} \right) \frac{du^h}{dx} dx - \int_0^l \frac{du^h}{da_k} f dx - \frac{du^h}{da_k} \bar{T} \Big|_0^l \\ &= \int_0^l \frac{d}{da_k} \left( \sum_{i=1}^m a_i \frac{dg_i}{dx} \right) \left( \sum_{i=1}^m a_i \frac{dg_i}{dx} \right) dx - \int_0^l \frac{d}{da_k} \left( \sum_{i=1}^m a_i g_i \right) f dx - \frac{d}{da_k} \sum_{i=1}^m a_i g_i \bar{T} \Big|_0^l \\ &= \sum_{i=1}^m \int_0^l \frac{dg_k}{dx} \frac{dg_i}{dx} dx a_i - \int_0^l g_k f dx - g_k \bar{T} \Big|_0^l = \sum_{i=1}^m K_{ki} a_i - F_k = 0 \quad \text{for } i=1, \dots, m\end{aligned}$$

$$\mathbf{Ka} = \mathbf{F}$$

- $\delta \Pi^{RR} = 0$ : **Variational Principle** or **Principle of Virtual Work**

$$\begin{aligned}\delta \Pi^{RR} &= \delta \left( \frac{1}{2} \int_0^l \frac{du^h}{dx} \frac{du^h}{dx} dx - \int_0^l u^h f dx - u^h \bar{T} \Big|_0^l \right) = \int_0^l \frac{d\delta u^h}{dx} \frac{du^h}{dx} dx - \int_0^l \delta u^h f dx - \delta u^h \bar{T} \Big|_0^l \\ &= \sum_{k=1}^m \delta a_k \left( \sum_{i=1}^m \int_0^l \frac{dg_k}{dx} \frac{dg_i}{dx} dx a_i - \int_0^l g_k f dx - g_k \bar{T} \Big|_0^l \right) \\ &= \sum_{k=1}^m \delta a_k \left( \sum_{i=1}^m K_{ki} a_i - F_k \right) = 0 \rightarrow (\delta \mathbf{a})^T (\mathbf{Ka} - \mathbf{F}) = 0\end{aligned}$$

- **Absolute Minimum Property of Total Potential Energy by the Exact Solution**

$$u^h = u - u^e$$

$$\begin{aligned}\Pi^h &= \frac{1}{2} \int_0^l \frac{du^h}{dx} \frac{du^h}{dx} dx - \int_0^l u^h f dx - u^h \bar{T} \Big|_0^l \\ &= \frac{1}{2} \int_0^l \frac{d(u - u^e)}{dx} \frac{d(u - u^e)}{dx} dx - \int_0^l (u - u^e) f dx - (u - u^e) \bar{T} \Big|_0^l \\ &= \frac{1}{2} \int_0^l \frac{du}{dx} \frac{du}{dx} dx - \int_0^l u f dx - u \bar{T} \Big|_0^l + \frac{1}{2} \int_0^l \frac{du^e}{dx} \frac{du^e}{dx} dx - \int_0^l \frac{du^e}{dx} \frac{du}{dx} dx + \int_0^l u^e f dx + u^e \bar{T} \Big|_0^l \\ &= \frac{1}{2} \int_0^l \frac{du}{dx} \frac{du}{dx} dx - \int_0^l u f dx - u \bar{T} \Big|_0^l + \frac{1}{2} \int_0^l \frac{du^e}{dx} \frac{du^e}{dx} dx - u^e \frac{du}{dx} \Big|_0^l + \int_0^l u^e \frac{d^2 u}{dx^2} dx + \int_0^l u^e f dx + u^e \bar{T} \Big|_0^l \\ &= \frac{1}{2} \int_0^l \frac{du}{dx} \frac{du}{dx} dx - \int_0^l u f dx - u \bar{T} \Big|_0^l + \frac{1}{2} \int_0^l \frac{du^e}{dx} \frac{du^e}{dx} dx + \int_0^l u^e \left( \frac{d^2 u}{dx^2} + f \right) dx + u^e \left( \bar{T} - \frac{du}{dx} \right) \Big|_0^l \\ &= \frac{1}{2} \int_0^l \frac{du}{dx} \frac{du}{dx} dx - \int_0^l u f dx - u \bar{T} \Big|_0^l + \frac{1}{2} \int_0^l \frac{du^e}{dx} \frac{du^e}{dx} dx \\ &= \Pi^E + \frac{1}{2} \int_0^l \left( \frac{du^e}{dx} \right)^2 dx \geq \Pi^E \quad (\text{The equality sign holds only for } u^e = C)\end{aligned}$$

- **Weighted Residual Method**

$$\begin{aligned}
 \pi_k &= \int_0^l g_k R_E dx + g_k \left( \frac{du}{dx} - \frac{du^h}{dx} \right) \Big|_0^l = \int_0^l g_k \left( \frac{d^2 u^h}{dx^2} + f \right) dx + g_k \left( \frac{du}{dx} - \frac{du^h}{dx} \right) \Big|_0^l \\
 &= g_k \frac{du^h}{dx} \Big|_0^l - \int_0^l \frac{dg_k}{dx} \frac{du^h}{dx} dx + \int_0^l g_k f dx + g_k \left( \frac{du}{dx} - \frac{du^h}{dx} \right) \Big|_0^l \\
 &= - \int_0^l \frac{dg_k}{dx} \frac{du^h}{dx} dx + \int_0^l g_k f dx + g_k \bar{T} \Big|_0^l \\
 &= - \sum_{i=1}^m \int_0^l \frac{dg_k}{dx} \frac{dg_i}{dx} dx a_i + \int_0^l g_k f dx + g_k \bar{T} \Big|_0^l = 0 \quad \text{for } k = 1, \dots, m \rightarrow \mathbf{Ka} = \mathbf{F}
 \end{aligned}$$

- **Weighted Residual vs. Variational Principle**

$$\begin{aligned}
 \pi_k = 0 \quad \text{for } k = 1, \dots, m &\Leftrightarrow \sum_{i=1}^m \pi_i \delta a_i = 0 \quad \text{for all possible } \delta a_i \\
 \sum_{k=1}^m \delta a_k \left( - \int_0^l \frac{dg_k}{dx} \frac{du^h}{dx} dx + \int_0^l g_k f dx + g_k \bar{T} \Big|_0^l \right) \\
 &= \sum_{k=1}^m \left( - \int_0^l \frac{d\delta a_k}{dx} g_k \frac{du^h}{dx} dx + \int_0^l \delta a_k g_k f dx + \delta a_k g_k \bar{T} \Big|_0^l \right) \\
 &= - \int_0^l \frac{d\delta u^h}{dx} \frac{du^h}{dx} dx + \int_0^l \delta u^h f dx + \delta u^h \bar{T} \Big|_0^l = \delta \Pi^{RR} = 0
 \end{aligned}$$

### 3.3. Integrability Condition - Regularity (continuity) Requirement

- Integration of functions with discontinuity  $\int_{-l}^l f(u(x))dx$  ??

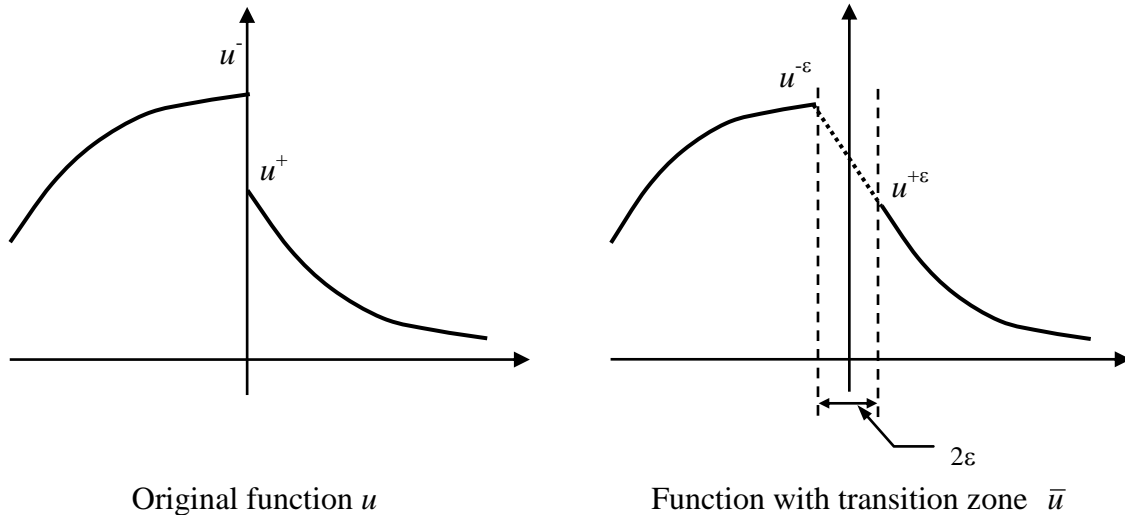

$$\int_{-l}^l f(u(x))dx = \lim_{\epsilon \rightarrow 0} \int_{-l}^l f(\bar{u}(x))dx$$

where  $\bar{u} = \begin{cases} u & \text{for } -l \leq x \leq -\epsilon \\ \frac{u^{+\epsilon} - u^{-\epsilon}}{2\epsilon} x + \frac{u^{+\epsilon} + u^{-\epsilon}}{2} & \text{for } -\epsilon \leq x \leq \epsilon \\ u & \text{for } \epsilon \leq x \leq l \end{cases}$ ,  $u^{+\epsilon} = u(\epsilon)$ ,  $u^{-\epsilon} = u(-\epsilon)$

- Can we integrate  $\int_{-l}^l u dx$  on what condition ?

$$\int_{-l}^l \bar{u} dx = \int_{-l}^{-\epsilon} \bar{u} dx + \int_{-\epsilon}^{\epsilon} \bar{u} dx + \int_{\epsilon}^l \bar{u} dx$$

$$\int_{-\epsilon}^{\epsilon} \bar{u} dx = \int_{-\epsilon}^{\epsilon} \left( \frac{u^{+\epsilon} - u^{-\epsilon}}{2\epsilon} x + \frac{u^{+\epsilon} + u^{-\epsilon}}{2} \right) dx = (u^{+\epsilon} + u^{-\epsilon})\epsilon$$

$$\int_{-l}^l u dx = \lim_{\epsilon \rightarrow 0} \left( \int_{-l}^{-\epsilon} \bar{u} dx + \int_{-\epsilon}^{\epsilon} \bar{u} dx + \int_{\epsilon}^l \bar{u} dx \right) = \lim_{\epsilon \rightarrow 0} \left( \int_{-l}^{-\epsilon} \bar{u} dx + \int_{\epsilon}^l \bar{u} dx + (u^{+\epsilon} + u^{-\epsilon})\epsilon \right)$$

The last integral vanishes as far as  $u^{-\epsilon}$  and  $u^{+\epsilon}$  are finite, and the integral becomes

$$\int_{-l}^l u dx = \int_{-l}^0 u dx + \int_0^l u dx$$

- Can we integrate  $\int_{-l}^l u^2 dx$  on what condition ?

$$\int_{-l}^l \bar{u}^2 dx = \int_{-l}^{-\varepsilon} \bar{u}^2 dx + \int_{-\varepsilon}^{\varepsilon} \bar{u}^2 dx + \int_{\varepsilon}^l \bar{u}^2 dx$$

$$\int_{-\varepsilon}^{\varepsilon} \bar{u}^2 dx = \int_{-\varepsilon}^{\varepsilon} \left( \frac{u^{+\varepsilon} - u^{-\varepsilon}}{2\varepsilon} x + \frac{u^{+\varepsilon} + u^{-\varepsilon}}{2} \right)^2 dx = (u^{+\varepsilon} - u^{-\varepsilon})^2 \frac{\varepsilon}{6} + (u^{+\varepsilon} + u^{-\varepsilon})^2 \frac{\varepsilon}{2}$$

$$\begin{aligned} \int_{-l}^l u^2 dx &= \lim_{\varepsilon \rightarrow 0} \left( \int_{-l}^{-\varepsilon} \bar{u}^2 dx + \int_{-\varepsilon}^{\varepsilon} \bar{u}^2 dx + \int_{\varepsilon}^l \bar{u}^2 dx \right) \\ &= \lim_{\varepsilon \rightarrow 0} \left( \int_{-l}^{-\varepsilon} \bar{u}^2 dx + \int_{\varepsilon}^l \bar{u}^2 dx + (u^{+\varepsilon} - u^{-\varepsilon})^2 \frac{\varepsilon}{6} + (u^{+\varepsilon} + u^{-\varepsilon})^2 \frac{\varepsilon}{2} \right) \end{aligned}$$

The last integral vanishes as far as  $u^{+\varepsilon}$  and  $u^{-\varepsilon}$  are finite, and the integral becomes

$$\int_{-l}^l u^2 dx = \int_{-l}^0 u^2 dx + \int_0^l u^2 dx$$

- Can we integrate  $\int_{-l}^l \left(\frac{du}{dx}\right)^2 dx$  ??

$$\begin{aligned} \int_{-l}^l \left(\frac{d\bar{u}}{dx}\right)^2 dx &= \int_{-l}^{-\varepsilon} \left(\frac{d\bar{u}}{dx}\right)^2 dx + \int_{-\varepsilon}^{\varepsilon} \left(\frac{d\bar{u}}{dx}\right)^2 dx + \int_{\varepsilon}^l \left(\frac{d\bar{u}}{dx}\right)^2 dx \\ &= \int_{-l}^{-\varepsilon} \left(\frac{d\bar{u}}{dx}\right)^2 dx + \int_{-\varepsilon}^{\varepsilon} \left(\frac{u^{+\varepsilon} - u^{-\varepsilon}}{2\varepsilon}\right)^2 dx + \int_{\varepsilon}^l \left(\frac{d\bar{u}}{dx}\right)^2 dx \\ &= \int_{-l}^{-\varepsilon} \left(\frac{d\bar{u}}{dx}\right)^2 dx + \frac{(u^{+\varepsilon} - u^{-\varepsilon})^2}{2\varepsilon} + \int_{\varepsilon}^l \left(\frac{d\bar{u}}{dx}\right)^2 dx \end{aligned}$$

$$\int_{-l}^l \left(\frac{du}{dx}\right)^2 dx = \lim_{\varepsilon \rightarrow 0} \int_{-l}^{-\varepsilon} \left(\frac{d\bar{u}}{dx}\right)^2 dx + \int_{-l}^0 \left(\frac{du}{dx}\right)^2 dx + \int_0^l \left(\frac{du}{dx}\right)^2 dx + \lim_{\varepsilon \rightarrow 0} \frac{(u^{+\varepsilon} - u^{-\varepsilon})^2}{2\varepsilon}$$

Therefore, the given definite integral has a finite value if and only if  $u$  is continuous.

$$\lim_{\varepsilon \rightarrow 0} u(+\varepsilon) = \lim_{\varepsilon \rightarrow 0} u(-\varepsilon)$$

From the physical point of view, the aforementioned continuity condition represents the **compatibility condition**, which states that the displacement field in a continuum should be uniquely determined, ie, defined by single valued functions.

- Can we integrate  $\int_{-l}^l u \frac{du}{dx} dx$  on what condition ?

$$\begin{aligned} \int_{-l}^l \bar{u} \frac{d\bar{u}}{dx} dx &= \int_{-l}^{-\varepsilon} \bar{u} \frac{d\bar{u}}{dx} dx + \int_{-\varepsilon}^{\varepsilon} \bar{u} \frac{d\bar{u}}{dx} dx + \int_{\varepsilon}^l \bar{u} \frac{d\bar{u}}{dx} dx \\ \int_{-\varepsilon}^{\varepsilon} \bar{u} \frac{d\bar{u}}{dx} dx &= \int_{-\varepsilon}^{\varepsilon} \left( \frac{u^{+\varepsilon} - u^{-\varepsilon}}{2\varepsilon} x + \frac{u^{+\varepsilon} + u^{-\varepsilon}}{2} \right) \left( \frac{u^{+\varepsilon} - u^{-\varepsilon}}{2\varepsilon} \right) dx = (u^{+\varepsilon} - u^{-\varepsilon}) \frac{(u^{+\varepsilon} + u^{-\varepsilon})}{2} \quad \text{or} \\ \int_{-\varepsilon}^{\varepsilon} \bar{u} \frac{d\bar{u}}{dx} dx &= \bar{u}^2 \Big|_{-\varepsilon}^{\varepsilon} - \int_{-\varepsilon}^{\varepsilon} \frac{d\bar{u}}{dx} \bar{u} dx \rightarrow \int_{-\varepsilon}^{\varepsilon} \frac{d\bar{u}}{dx} \bar{u} dx = \frac{1}{2} (u^2(\varepsilon) - u^2(-\varepsilon)) = (u^{+\varepsilon} - u^{-\varepsilon}) \frac{(u^{+\varepsilon} + u^{-\varepsilon})}{2} \\ \int_{-l}^l u \frac{du}{dx} dx &= \lim_{\varepsilon \rightarrow 0} \left( \int_{-l}^{-\varepsilon} \bar{u} \frac{d\bar{u}}{dx} dx + \int_{-\varepsilon}^{\varepsilon} \bar{u} \frac{d\bar{u}}{dx} dx + \int_{\varepsilon}^l \bar{u} \frac{d\bar{u}}{dx} dx \right) \\ &= \lim_{\varepsilon \rightarrow 0} \left( \int_{-l}^{-\varepsilon} \bar{u} \frac{d\bar{u}}{dx} dx + \int_{\varepsilon}^l \bar{u} \frac{d\bar{u}}{dx} dx + (u^{+\varepsilon} - u^{-\varepsilon}) \frac{(u^{+\varepsilon} + u^{-\varepsilon})}{2} \right) \\ &= \int_{-l}^0 u \frac{du}{dx} dx + \int_0^l u \frac{du}{dx} dx + (u^+ - u^-) \frac{(u^+ + u^-)}{2} \\ &= \int_{-l}^0 u \frac{du}{dx} dx + \int_0^l u \frac{du}{dx} dx + [u]^{\pm} (u)^{\pm} \end{aligned}$$

Therefore, the given definite integral has a unique & finite value even if  $u$  is discontinuous.

### ● Homework 3

1. Derive  $\Pi^R$ ,  $\Pi^{LS}$ ,  $\Pi^{RR}$  for the following ODE with the homogeneous displacement BCs.

$$\frac{d^4 w}{dx^4} - q = 0$$

2. Prove the absolute minimum property of  $\Pi^{RR}$  derived in Prob. 1 by the exact solution.

3. Approximate solutions for a cantilever beam subject to a uniform load ( $q$ ) over the span and a concentrate load applied at the free end by polynomials with one unknown, two unknowns and three unknowns. Compare your solutions including displacement, rotation, moment and shear force to exact solution and discuss.

4. Identify the integrability condition for the following integrals, and evaluate the integrals for the identified condition.

$$\int_0^l \left( \frac{d^2 w}{dx^2} \right)^2 dx \quad \text{and} \quad \int_0^l \frac{dw}{dx} \frac{d^2 w}{dx^2} dx$$



### 3.4. The Other Side of the Principle of Virtual Work

- **Physical Viewpoint**

If a deformable body is in equilibrium under a  $Q$ -force system and remains in equilibrium while it is subjected a small virtual deformation, the external virtual work done by external  $Q$  forces acting on the body is equal to the internal virtual work of deformation done by the internal  $Q$ -stresses.

$$\int_S \delta u_i Q_i dS = \int_V \delta \varepsilon_{ij} \sigma_{ij} dV \quad \text{where} \quad \delta \varepsilon_{ij} = \frac{1}{2} \left( \frac{\partial \delta u_i}{\partial x_j} + \frac{\partial \delta u_j}{\partial x_i} \right)$$

- **Mathematical Viewpoint - Continuous Problem**

If  $\mathbf{A}(\mathbf{u}) = 0$  should hold for a given system, then the following statement should hold. Here,  $\mathbf{u} \in \mathfrak{U}$ , and the order of  $\mathbf{A}$  should be the same as  $\mathbf{u}$ .

$$\int_V \delta \mathbf{u} \cdot \mathbf{A}(\mathbf{u}) dV = 0 \quad \forall \delta \mathbf{u} \in \mathfrak{U} \quad (\mathfrak{U}: \text{A proper Function space})$$

- Example : Beam problem

The governing equation for a beam problem :  $EI \frac{d^4 w}{dx^4} = q$

The expression for virtual work :

$$\int_V \delta w (EI \frac{d^4 w}{dx^4} - q) dx = 0 \rightarrow \int_V \frac{d^2 \delta w}{dx^2} EI \frac{d^2 w}{dx^2} dx = \int_V \delta w q dx$$

If  $\delta w$  is the displacement induced by the unit load applied load at  $x_j$ , the expression for the principle of virtual work becomes as follows.

$$\int_V \frac{M^u M^Q}{EI} dx = \int_V \delta w q dx = \int_V w \delta(x - x_j) dx = w(x_j)$$

where  $M^u$  is the moment induced by the unit load applied at  $x_j$  and  $\delta(x - x_j)$  is a delac delta function applied at  $x_j$ .

• **Mathematical Viewpoint - Discrete Problem**

$$\delta \mathbf{u} \cdot \mathbf{A}(\mathbf{u}) = \delta u_i \cdot A_i(\mathbf{u}) = 0 \quad \forall \delta \mathbf{u} \in \mathcal{V} \quad (\mathcal{V} : \text{A proper Function space})$$

- Example : Truss problem

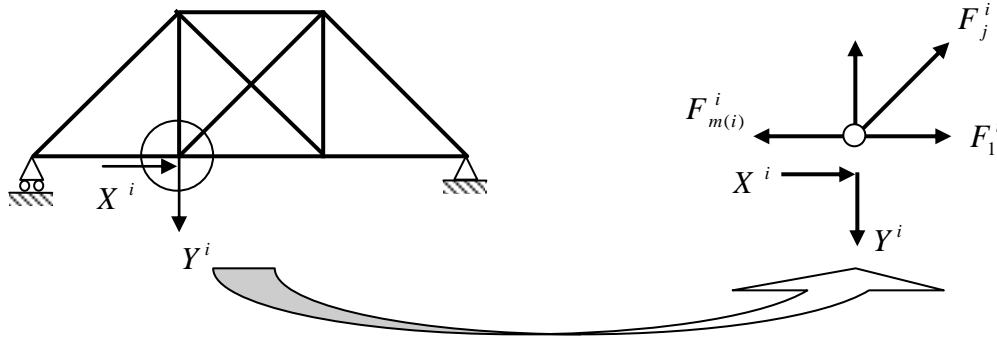

Equilibrium Equations at joints

$$\sum_{j=1}^{m(i)} H_j^i + X^i = 0, \quad \sum_{j=1}^{m(i)} V_j^i + Y^i = 0 \quad \text{for } i=1, \dots, n$$

Virtual Work Expression

$$\sum_{i=1}^n ((\sum_{j=1}^{m(i)} H_j^i + X^i) \delta u^i + (\sum_{j=1}^{m(i)} V_j^i + Y^i) \delta v^i) = 0$$

$$\sum_{i=1}^n ((-\sum_{j=1}^{m(i)} F_j^i \cos \theta_j + X^i) \delta u^i + (-\sum_{j=1}^{m(i)} F_j^i \sin \theta_j + Y^i) \delta v^i) = 0$$

$$\sum_{i=1}^n (\delta u^i \sum_{j=1}^{m(i)} F_j^i \cos \theta_j + \delta v^i \sum_{j=1}^{m(i)} F_j^i \sin \theta_j) = \sum_{i=1}^n (X^i \delta u^i + Y^i \delta v^i)$$

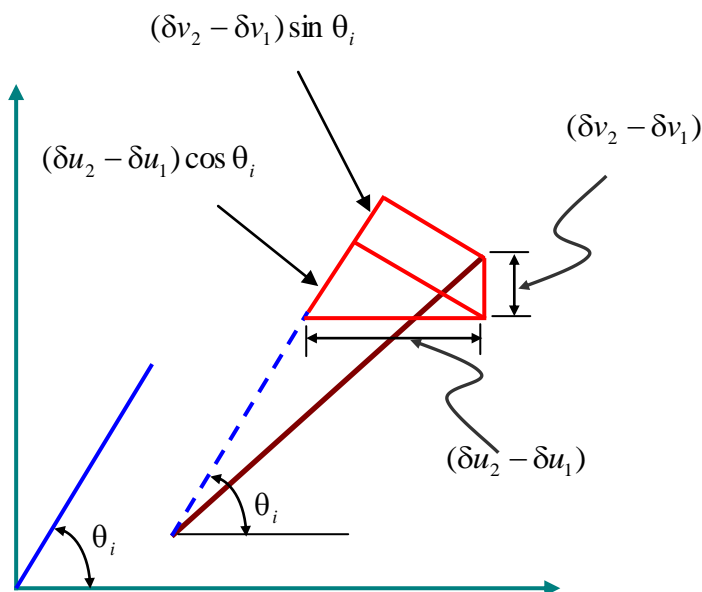

$$\begin{aligned} & \sum_{i=1}^{nmb} (F^i \cos \theta_i (\delta u_2^i - \delta u_1^i) + F^i \sin \theta_i (\delta v_2^i - \delta v_1^i)) = \\ & \sum_{i=1}^{nmb} F^i ((\delta u_2^i - \delta u_1^i) \cos \theta_i + (\delta v_2^i - \delta v_1^i) \sin \theta_i) = \\ & \sum_{i=1}^{nmb} F^i \Delta l_\mu^i = \sum_{i=1}^{nmb} F^i \frac{\mu^i l^i}{(EA^i)} = \sum_{i=1}^{nmb} \frac{F^i \mu^i l^i}{(EA^i)} = \sum_{i=1}^n (X^i \delta u^i + Y^i \delta v^i) = \sum_{i=1}^n (X_\mu^i u^i + Y_\mu^i v^i) \end{aligned}$$

If  $\mu$  force system consists of an unit load applied at  $k$ -th joint in arbitrary direction, then

$$X_\mu^k u^k + Y_\mu^k v^k = \|\mathbf{X}\| \|\mathbf{u}\| \cos \theta = \|\mathbf{u}\| \cos \theta = \sum_{i=1}^{nmb} \frac{F^i \mu^i l^i}{(EA^i)}$$

### 3.5. Finite Element Discretization

- Domain Discretization

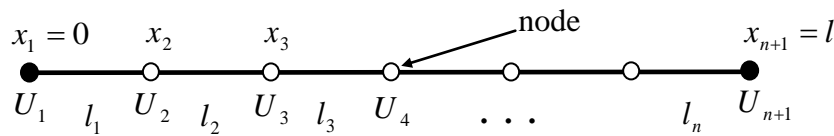

$$\begin{aligned} \delta \Pi &= \int_0^l \frac{d\delta u^h}{dx} \frac{du^h}{dx} dx - \int_0^l f \delta u^h dx - \delta u^h \bar{T} \Big|_0^l \\ &= \sum_{e=1}^n \int_{l_e} \frac{d\delta u^h}{dx} \frac{du^h}{dx} dx - \sum_{e=1}^n \int_{l_e} f \delta u^h dx - \delta u^h \bar{T} \Big|_0^l \\ &= \sum_e \int_{l_e} \frac{d\delta u^h}{dx} \frac{du^h}{dx} dx - \sum_e \int_{l_e} f \delta u^h dx - \delta u^h \bar{T} \Big|_0^l = 0 \text{ for all admissible } \delta u^h \end{aligned}$$

- Interpolation of Displacement Field in an Element

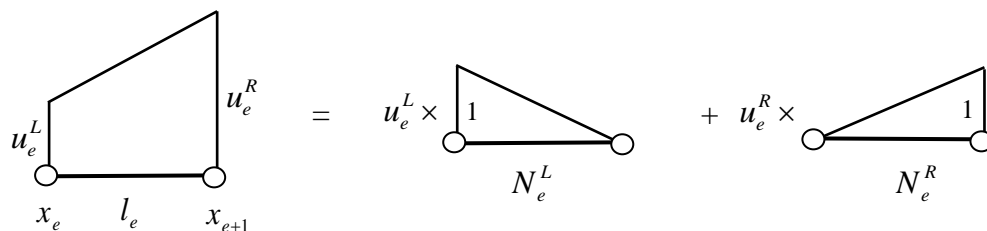

$$u_e^h(x) = N_e^L u_e^L + N_e^R u_e^R = (N_e^L, N_e^R) \begin{pmatrix} u_e^L \\ u_e^R \end{pmatrix} = \mathbf{N} \cdot \mathbf{u}_e$$

$$\delta u_e^h(x) = N_e^L \delta u_e^L + N_e^R \delta u_e^R = (N_e^L, N_e^R) \begin{pmatrix} \delta u_e^L \\ \delta u_e^R \end{pmatrix} = \mathbf{N} \cdot \delta \mathbf{u}_e$$

$$N_e^L = \frac{x_{e+1} - x}{x_{e+1} - x_e} = \frac{x_{e+1} - x}{l_e}, \quad N_e^R = \frac{x - x_e}{x_{e+1} - x_e} = \frac{x - x_e}{l_e}$$

- **Discretized Form of Variational Statement**

$$\frac{du_e^h}{dx} = \frac{dN_e^L}{dx} u_e^L + \frac{dN_e^R}{dx} u_e^R = \left( \frac{dN_e^L}{dx}, \frac{dN_e^R}{dx} \right) \begin{pmatrix} u_e^L \\ u_e^R \end{pmatrix} = \mathbf{B} \cdot \mathbf{u}_e$$

$$\frac{d\delta u_e^h}{dx} = \frac{dN_e^L}{dx} \delta u_e^L + \frac{dN_e^R}{dx} \delta u_e^R = \left( \frac{dN_e^L}{dx}, \frac{dN_e^R}{dx} \right) \begin{pmatrix} \delta u_e^L \\ \delta u_e^R \end{pmatrix} = \mathbf{B} \cdot \delta \mathbf{u}_e$$

$$\begin{aligned} \delta \Pi &= \sum_e \int_{l_e} \frac{d\delta u_e^h}{dx} \frac{du_e^h}{dx} dx - \sum_e \int_{l_e} f \delta u_e^h dx - \delta u_e^h \bar{T} \Big|_0^l \\ &= \sum_e \int_{l_e} \left( \frac{d\delta u_e^h}{dx} \right)^T \frac{du_e^h}{dx} dx - \sum_e \int_{l_e} (\delta u_e^h)^T f dx - (\delta u_e^R(l) \bar{T}(l) - \delta u_e^L(0) \bar{T}(0)) \\ &= \sum_e \delta \mathbf{u}_e^T \int_{l_e} \mathbf{B}^T \mathbf{B} dx \mathbf{u}_e - \sum_e \delta \mathbf{u}_e^T \int_{l_e} \mathbf{N}^T f dx - \delta \mathbf{u}^b \bar{\mathbf{T}} \\ &= \sum_e \delta \mathbf{u}_e^T \mathbf{K}_e \mathbf{u}_e - \sum_e \delta \mathbf{u}_e^T \mathbf{F}_e - \delta \mathbf{u}^b \bar{\mathbf{T}} = 0 \end{aligned}$$

- **Compatibility Condition – Continuity Requirement**

$$u_e^L = u_{e-1}^R = U^e, \quad u_e^R = u_{e+1}^L = U^{e+1}$$

$$\mathbf{u}_e = \begin{pmatrix} u_e^L \\ u_e^R \end{pmatrix} = \begin{bmatrix} 0 & \cdots & 1 & 0 & \cdots & 0 \\ 0 & \cdots & 0 & 1 & \cdots & 0 \end{bmatrix} \begin{pmatrix} U^1 \\ \vdots \\ U^e \\ U^{e+1} \\ \vdots \\ U^{n+1} \end{pmatrix} = \mathbf{C}_e \mathbf{U}, \quad \delta \mathbf{u}_e = \mathbf{C}_e \delta \mathbf{U}$$

- **Global System Equation – Global Stiffness Equation**

$$\begin{aligned} \delta \Pi &= \sum_e \delta \mathbf{U}^T \mathbf{C}_e^T \mathbf{K}_e \mathbf{C}_e \mathbf{U} - \sum_e \delta \mathbf{U}^T \mathbf{C}_e^T \mathbf{F}_e - \delta \mathbf{U}^T \mathbf{C}_b^T \bar{\mathbf{T}} \\ &= \delta \mathbf{U}^T \left( \sum_e \mathbf{C}_e^T \mathbf{K}_e \mathbf{C}_e \right) \mathbf{U} - \delta \mathbf{U}^T \left( \sum_e \mathbf{C}_e^T \mathbf{F}_e - \mathbf{C}_b^T \bar{\mathbf{T}} \right) \rightarrow \underline{\underline{\mathbf{K} \mathbf{U} = \mathbf{F}}} \\ &= \delta \mathbf{U}^T (\mathbf{K} \mathbf{U} - \mathbf{F}) = 0 \text{ for all admissible } \delta \mathbf{U} \end{aligned}$$

## • Rayleigh-Ritz Type Interpretation of FEM

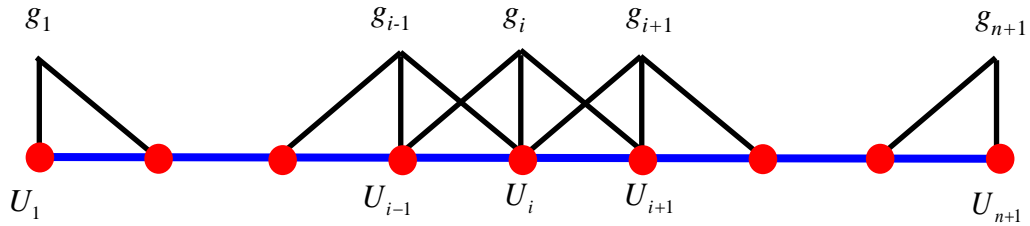

$$u^h = g_i U_i$$

$$\int_0^l \frac{d\delta u^h}{dx} \frac{du^h}{dx} dx = \int_0^l \delta u^h f dx \quad \text{for all admissible } \delta u^h$$

$$\int_0^l \frac{d\delta u^h}{dx} \frac{du^h}{dx} dx = \sum_{i=1}^{n+1} \delta U_i \sum_{j=1}^{n+1} \int_0^l \frac{dg_i}{dx} \frac{dg_j}{dx} dx U_j =$$

$$\delta U_1 \int_{x_1}^{x_2} \frac{dg_1}{dx} \left( \frac{dg_1}{dx} U_1 + \frac{dg_2}{dx} U_2 \right) dx +$$

$$\delta U_2 \int_{x_1}^{x_2} \frac{dg_2}{dx} \left( \frac{dg_1}{dx} U_1 + \frac{dg_2}{dx} U_2 \right) dx \quad + \delta U_2 \int_{x_2}^{x_3} \frac{dg_2}{dx} \left( \frac{dg_2}{dx} U_2 + \frac{dg_3}{dx} U_3 \right) dx +$$

...

$$\delta U_{i-1} \int_{x_{i-2}}^{x_{i-1}} \frac{dg_{i-1}}{dx} \left( \frac{dg_{i-2}}{dx} U_{i-2} + \frac{dg_{i-1}}{dx} U_{i-1} \right) dx + \delta U_{i-1} \int_{x_{i-1}}^{x_i} \frac{dg_{i-1}}{dx} \left( \frac{dg_{i-1}}{dx} U_{i-1} + \frac{dg_i}{dx} U_i \right) dx +$$

$$\delta U_i \int_{x_{i-1}}^{x_i} \frac{dg_i}{dx} \left( \frac{dg_{i-1}}{dx} U_{i-1} + \frac{dg_i}{dx} U_i \right) dx \quad + \delta U_i \int_{x_i}^{x_{i+1}} \frac{dg_i}{dx} \left( \frac{dg_i}{dx} U_i + \frac{dg_{i+1}}{dx} U_{i+1} \right) dx +$$

$$\delta U_{i+1} \int_{x_i}^{x_{i+1}} \frac{dg_{i+1}}{dx} \left( \frac{dg_i}{dx} U_i + \frac{dg_{i+1}}{dx} U_{i+1} \right) dx \quad + \delta U_{i+1} \int_{x_{i+1}}^{x_{i+2}} \frac{dg_{i+1}}{dx} \left( \frac{dg_{i+1}}{dx} U_{i+1} + \frac{dg_{i+2}}{dx} U_{i+2} \right) dx +$$

...

$$\delta U_n \int_{x_{n-1}}^{x_n} \frac{dg_n}{dx} \left( \frac{dg_{n-1}}{dx} U_{n-1} + \frac{dg_n}{dx} U_n \right) dx \quad + \delta U_n \int_{x_n}^{x_{n+1}} \frac{dg_n}{dx} \left( \frac{dg_n}{dx} U_n + \frac{dg_{n+1}}{dx} U_{n+1} \right) dx +$$

$$\delta U_{n+1} \int_{x_n}^{x_{n+1}} \frac{dg_{n+1}}{dx} \left( \frac{dg_n}{dx} U_n + \frac{dg_{n+1}}{dx} U_{n+1} \right) dx$$

$$= \sum_{i=1}^n \int_{x_i}^{x_{i+1}} \left( \delta U_i \frac{dg_i}{dx} + \delta U_{i+1} \frac{dg_{i+1}}{dx} \right) \left( \frac{dg_i}{dx} U_i + \frac{dg_{i+1}}{dx} U_{i+1} \right) dx$$

$$= \sum_e \delta \mathbf{U}_e^T \int_{x_i}^{x_{i+1}} \mathbf{B}^T \mathbf{B} dx \mathbf{U}_e$$

- **Finite Element Procedure**

1. Governing equations in the domain, boundary conditions on the boundary.
2. Derive weak form of the G.E. and B.C. by the variational principle or equivalent.
3. Discretize the given domain and boundary with finite elements.

$$V = V^1 \cup V^2 \cup \dots \cup V^n \quad , \quad S = S^1 \cup S^2 \cup \dots \cup S^m$$

4. Assume the displacement field by shape functions and nodal values within an element.

$$\mathbf{u}^e = \mathbf{N}^e \mathbf{U}^e$$

5. Calculate the element stiffness matrix and assemble it according to the compatibility.

$$\mathbf{K}^e = \int_{l^e} \mathbf{B}^T \mathbf{D} \mathbf{B} dV, \quad \mathbf{K} = \sum_e \mathbf{K}^e$$

6. Calculate the equivalent nodal force and assemble it according to the compatibility.

$$\mathbf{F}^e = \int_{l^e} \mathbf{N}^T f dV + \mathbf{N}^T \bar{\mathbf{T}}|_0^l, \quad \mathbf{F} = \sum_e \mathbf{F}^e$$

7. Apply the displacement boundary conditions and solve the stiffness equation.
8. Calculate strain, stress and reaction force.

- **Example with Three Elements and Four Nodes**

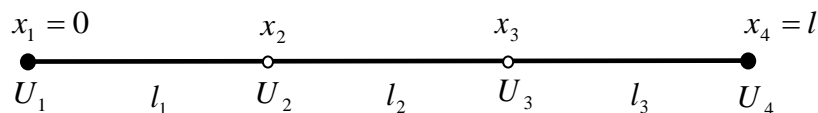

- *Shape Function Matrix*

$$u_e^h(x) = N_e^L u_e^L + N_e^R u_e^R = (N_e^L, N_e^R) \begin{pmatrix} u_e^L \\ u_e^R \end{pmatrix} = \mathbf{N}_e \cdot \mathbf{u}_e$$

$$N_e^L = \frac{x_{e+1} - x}{x_{e+1} - x_e} = \frac{x_{e+1} - x}{l_e}, \quad N_e^R = \frac{x - x_e}{x_{e+1} - x_e} = \frac{x - x_e}{l_e}$$

$$\mathbf{B}_e = \left( \frac{dN_e^L}{dx}, \frac{dN_e^R}{dx} \right) = \frac{1}{l_e} [-1, 1]$$

- *Element Stiffness Matrix*

$$[\mathbf{K}]_e = \int_{V_e} \frac{1}{l_e} \begin{pmatrix} -1 \\ 1 \end{pmatrix} \frac{1}{l_e} [-1, 1] dx = \frac{1}{l_e} \begin{bmatrix} 1 & -1 \\ -1 & 1 \end{bmatrix}$$

- *Compatibility Matrix*

$$\mathbf{u}_1 = \begin{pmatrix} u_1^L \\ u_1^R \end{pmatrix} = \begin{bmatrix} 1 & 0 & 0 & 0 \\ 0 & 1 & 0 & 0 \end{bmatrix} \begin{pmatrix} U_1 \\ U_2 \\ U_3 \\ U_4 \end{pmatrix} = \mathbf{C}_1 \mathbf{U}, \quad \mathbf{u}_2 = \begin{pmatrix} u_2^L \\ u_2^R \end{pmatrix} = \begin{bmatrix} 0 & 1 & 0 & 0 \\ 0 & 0 & 1 & 0 \end{bmatrix} \begin{pmatrix} U_1 \\ U_2 \\ U_3 \\ U_4 \end{pmatrix} = \mathbf{C}_2 \mathbf{U}$$

$$\mathbf{u}_3 = \begin{pmatrix} u_3^L \\ u_3^R \end{pmatrix} = \begin{bmatrix} 0 & 0 & 1 & 0 \\ 0 & 0 & 0 & 1 \end{bmatrix} \begin{pmatrix} U_1 \\ U_2 \\ U_3 \\ U_4 \end{pmatrix} = \mathbf{C}_3 \mathbf{U}$$

 - *Global Stiffness Matrix*

$$\mathbf{K} = \sum_e \mathbf{C}_e^T \mathbf{K}_e \mathbf{C}_e = \mathbf{C}_1^T \mathbf{K}_1 \mathbf{C}_1 + \mathbf{C}_2^T \mathbf{K}_2 \mathbf{C}_2 + \mathbf{C}_3^T \mathbf{K}_3 \mathbf{C}_3$$

$$= \frac{1}{l_1} \begin{bmatrix} 1 & 0 \\ 0 & 1 \\ 0 & 0 \\ 0 & 0 \end{bmatrix} \begin{bmatrix} 1 & -1 \\ -1 & 1 \end{bmatrix} \begin{bmatrix} 1 & 0 & 0 & 0 \\ 0 & 1 & 0 & 0 \end{bmatrix} + \frac{1}{l_2} \begin{bmatrix} 0 & 0 \\ 1 & 0 \\ 0 & 1 \\ 0 & 0 \end{bmatrix} \begin{bmatrix} 1 & -1 \\ -1 & 1 \end{bmatrix} \begin{bmatrix} 0 & 1 & 0 & 0 \\ 0 & 0 & 1 & 0 \end{bmatrix}$$

$$+ \frac{1}{l_3} \begin{bmatrix} 0 & 0 \\ 0 & 0 \\ 1 & 0 \\ 0 & 1 \end{bmatrix} \begin{bmatrix} 1 & -1 \\ -1 & 1 \end{bmatrix} \begin{bmatrix} 0 & 0 & 1 & 0 \\ 0 & 0 & 0 & 1 \end{bmatrix}$$

$$= \frac{1}{l_1} \begin{bmatrix} 1 & -1 & 0 & 0 \\ -1 & 1 & 0 & 0 \\ 0 & 0 & 0 & 0 \\ 0 & 0 & 0 & 0 \end{bmatrix} + \frac{1}{l_2} \begin{bmatrix} 0 & 0 & 0 & 0 \\ 0 & 1 & -1 & 0 \\ 0 & -1 & 1 & 0 \\ 0 & 0 & 0 & 0 \end{bmatrix} + \frac{1}{l_3} \begin{bmatrix} 0 & 0 & 0 & 0 \\ 0 & 0 & 0 & 0 \\ 0 & 0 & 1 & -1 \\ 0 & 0 & -1 & 1 \end{bmatrix}$$

$$= \begin{bmatrix} \frac{1}{l_1} & -\frac{1}{l_1} & 0 & 0 \\ -\frac{1}{l_1} & \frac{1}{l_1} + \frac{1}{l_2} & -\frac{1}{l_2} & 0 \\ 0 & -\frac{1}{l_2} & \frac{1}{l_2} + \frac{1}{l_3} & -\frac{1}{l_3} \\ 0 & 0 & -\frac{1}{l_3} & \frac{1}{l_3} \end{bmatrix}$$

- Force Term

$$\mathbf{F}_e = \frac{1}{l_e} \int_{x_e}^{x_{e+1}} (x_{e+1} - x) \cdot 1 dx = \frac{l_e}{2} \begin{pmatrix} 1 \\ 1 \end{pmatrix}$$

$$\mathbf{F} = \sum_e \mathbf{C}_e^T \mathbf{F}_e = \mathbf{C}_1^T \mathbf{F}_1 + \mathbf{C}_2^T \mathbf{F}_2 + \mathbf{C}_3^T \mathbf{F}_3$$

$$= \frac{l_1}{2} \begin{bmatrix} 1 & 0 \\ 0 & 1 \\ 0 & 0 \\ 0 & 0 \end{bmatrix} \begin{pmatrix} 1 \\ 1 \end{pmatrix} + \frac{l_2}{2} \begin{bmatrix} 0 & 0 \\ 1 & 0 \\ 0 & 1 \\ 0 & 0 \end{bmatrix} \begin{pmatrix} 1 \\ 1 \end{pmatrix} + \frac{l_3}{2} \begin{bmatrix} 0 & 0 \\ 0 & 0 \\ 1 & 0 \\ 0 & 1 \end{bmatrix} \begin{pmatrix} 1 \\ 1 \end{pmatrix} = \begin{pmatrix} \frac{l_1}{2} \\ \frac{l_1}{2} + \frac{l_2}{2} \\ \frac{l_2}{2} + \frac{l_3}{2} \\ \frac{l_3}{2} \end{pmatrix}$$

- System Equation

$$\begin{bmatrix} \frac{1}{l_1} & -\frac{1}{l_1} & 0 & 0 \\ -\frac{1}{l_1} & \frac{1}{l_1} + \frac{1}{l_2} & -\frac{1}{l_2} & 0 \\ 0 & -\frac{1}{l_2} & \frac{1}{l_2} + \frac{1}{l_3} & -\frac{1}{l_3} \\ 0 & 0 & -\frac{1}{l_3} & \frac{1}{l_3} \end{bmatrix} \begin{pmatrix} U^1 \\ U^2 \\ U^3 \\ U^4 \end{pmatrix} = \begin{pmatrix} \frac{l_1}{2} \\ \frac{l_1}{2} + \frac{l_2}{2} \\ \frac{l_2}{2} + \frac{l_3}{2} \\ \frac{l_3}{2} \end{pmatrix}$$

- Case 1:  $l_1 = l_2 = l_3 = \frac{1}{3}$   $u(0) = 0$ ,  $\frac{du(1)}{dx} = 0$

$$\begin{bmatrix} \frac{1}{l_1} & -\frac{1}{l_1} & 0 & 0 \\ -\frac{1}{l_1} & \frac{1}{l_1} + \frac{1}{l_2} & -\frac{1}{l_2} & 0 \\ 0 & -\frac{1}{l_2} & \frac{1}{l_2} + \frac{1}{l_3} & -\frac{1}{l_3} \\ 0 & 0 & -\frac{1}{l_3} & \frac{1}{l_3} \end{bmatrix} \begin{pmatrix} U^1 \\ U^2 \\ U^3 \\ U^4 \end{pmatrix} = \begin{pmatrix} \frac{l_1}{2} \\ \frac{l_1}{2} + \frac{l_2}{2} \\ \frac{l_2}{2} + \frac{l_3}{2} \\ \frac{l_3}{2} \end{pmatrix} \rightarrow \begin{bmatrix} 2 & -1 & 0 \\ -1 & 2 & -1 \\ 0 & -1 & 1 \end{bmatrix} \begin{pmatrix} U^2 \\ U^3 \\ U^4 \end{pmatrix} = \frac{1}{9} \begin{pmatrix} 1 \\ 1 \\ 0.5 \end{pmatrix}$$

$$U_2 = \frac{5}{18}, U_3 = \frac{8}{18}, U_4 = \frac{9}{18}$$

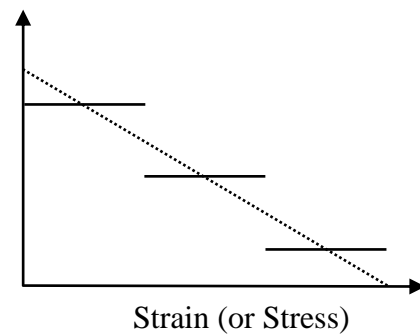
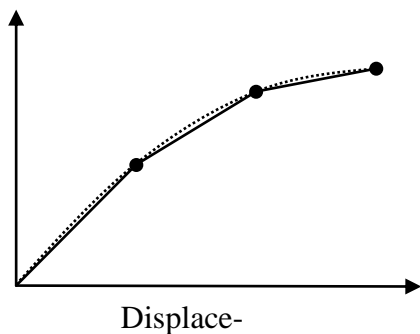



- Case 2 :  $l_1 = l_2 = l_3 = \frac{1}{3}$      $u(0) = 0$  ,  $u(1) = 0$

$$\begin{bmatrix} \frac{1}{l_1} & -\frac{1}{l_1} & 0 & 0 \\ -\frac{1}{l_1} & \frac{1}{l_1} + \frac{1}{l_2} & -\frac{1}{l_2} & 0 \\ 0 & -\frac{1}{l_2} & \frac{1}{l_2} + \frac{1}{l_3} & -\frac{1}{l_3} \\ 0 & 0 & -\frac{1}{l_3} & \frac{1}{l_3} \end{bmatrix} \begin{pmatrix} U^1 \\ U^2 \\ U^3 \\ U^4 \end{pmatrix} = \begin{pmatrix} \frac{l_1}{2} \\ \frac{l_1}{2} + \frac{l_2}{2} \\ \frac{l_2}{2} + \frac{l_3}{2} \\ \frac{l_3}{2} \end{pmatrix} \rightarrow \begin{bmatrix} 2 & -1 \\ -1 & 2 \end{bmatrix} \begin{pmatrix} U^2 \\ U^3 \end{pmatrix} = \frac{1}{9} \begin{pmatrix} 1 \\ 1 \end{pmatrix}$$

$$U_2 = \frac{1}{9}, U_3 = \frac{1}{9}$$

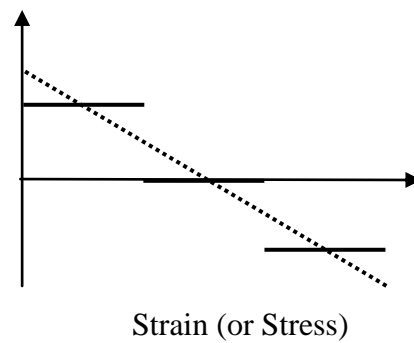
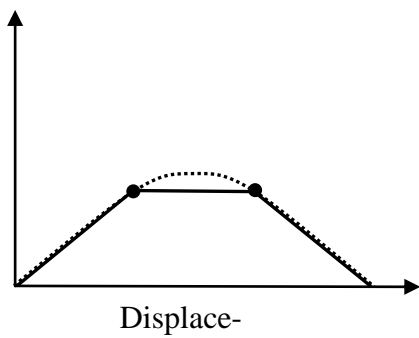

### 3.6. Finite Difference Discretization

- Differential Equation

$$\frac{d^2u}{dx^2} + f = 0 \rightarrow D^2u^i + f_i = 0 \quad \text{where } D^2 \text{ is a 2}^{\text{nd}}\text{-order finite difference operator.}$$

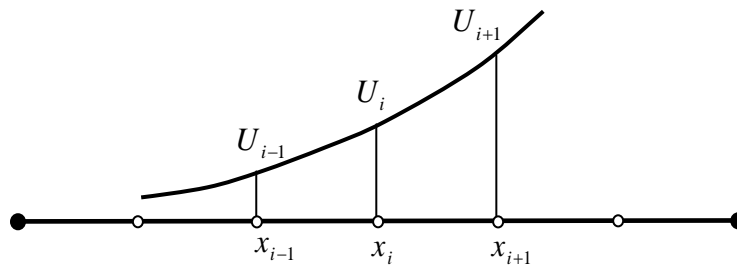

• **Finite Difference Operator (Central Difference)**

- Suppose  $u$  is approximated by a 2<sup>nd</sup>-order parabola ,ie,  $u \approx ax^2 + bx + c$

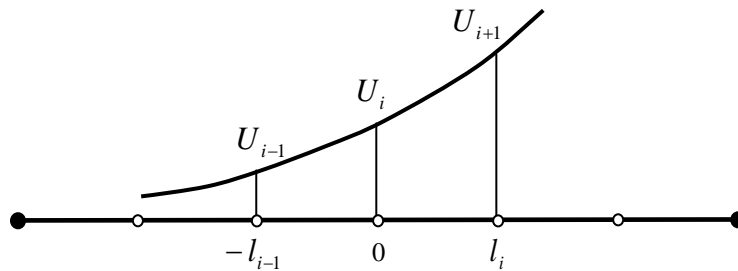

$$\left. \begin{aligned} U_{i-1} &= al_{i-1}^2 - bl_{i-1} + c \\ U_i &= c \\ U_{i+1} &= al_i^2 + bl_i + c \end{aligned} \right\} \rightarrow a = \frac{1}{l_{i-1} + l_i} \left( \frac{1}{l_{i-1}} U_{i-1} - \left( \frac{1}{l_{i-1}} + \frac{1}{l_i} \right) U_i + \frac{1}{l_i} U_{i+1} \right)$$

$$\left. \frac{d^2 u}{dx^2} \right|_{x=x_i} \approx D^2 u_i = 2a = \frac{2}{l_{i-1} + l_i} \left( \frac{1}{l_{i-1}} U_{i-1} - \left( \frac{1}{l_{i-1}} + \frac{1}{l_i} \right) U_i + \frac{1}{l_i} U_{i+1} \right)$$

• **Finite Difference Equations for interior nodes**

$$-\frac{1}{l_{i-1}} U_{i-1} + \left( \frac{1}{l_{i-1}} + \frac{1}{l_i} \right) U_i - \frac{1}{l_i} U_{i+1} = \frac{l_{i-1} + l_i}{2} f_i$$

• **Finite Difference Equations for Boundary Nodes with Displacement BCs**

In case that a displacement BC is specified at a boundary nodes, the finite difference equations need to be set up for only interior nodes. The BC can be applied to the finite difference equation for the node adjacent to the boundary nodes.

- Example – Case 2

$$\begin{aligned} -\cancel{\frac{1}{l_1} U_1} + \left( \frac{1}{l_1} + \frac{1}{l_2} \right) U_2 - \frac{1}{l_2} U_3 &= \frac{l_1 + l_2}{2} f_2 \\ -\frac{1}{l_2} U_2 + \left( \frac{1}{l_2} + \frac{1}{l_3} \right) U_3 - \cancel{\frac{1}{l_3} U_4} &= \frac{l_2 + l_3}{2} f_3 \end{aligned}$$

• **Finite Difference Equations for Boundary Nodes with Traction BCs**

In case that a traction BC is specified at a boundary nodes, a special treatment for boundary condition such as ghost node is introduced.

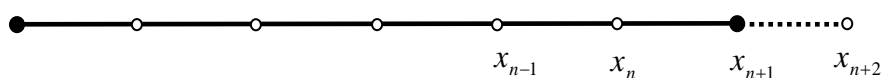

- The finite difference equation at the node  $n+1$  :

$$-\frac{1}{l_n}U_n + \left(\frac{1}{l_n} + \frac{1}{l_{n+1}}\right)U_{n+1} - \frac{1}{l_{n+1}}U_{n+2} = \frac{l_n + l_{n+1}}{2}f_{n+1}$$

- Approximation of the traction BC by the finite difference operator.

$$\left. \frac{du}{dx} \right|_{x=l} \approx \frac{U_{n+2} - U_n}{l_{n+1} + l_n} = 0 \rightarrow U_{n+2} = U_n$$

- Substitution of the FD traction BC into FD equations for the boundary node.

$$-\left(\frac{1}{l_n} + \frac{1}{l_{n+1}}\right)U_n + \left(\frac{1}{l_n} + \frac{1}{l_{n+1}}\right)U_{n+1} = \frac{l_n + l_{n+1}}{2}f_{n+1}$$

Since the location of the ghost node is arbitrary,  $l_{n+1} = l_n$  can be assumed without loss of generality. The final equation for the boundary node becomes

$$-\frac{1}{l_n}U_n + \frac{1}{l_n}U_{n+1} = \frac{l_n}{2}f_{n+1}$$

- *Example – Case 1*

$$-\frac{1}{l_1}U_1 + \left(\frac{1}{l_1} + \frac{1}{l_2}\right)U_2 - \frac{1}{l_2}U_3 = \frac{l_1 + l_2}{2}f_2$$

$$-\frac{1}{l_2}U_2 + \left(\frac{1}{l_2} + \frac{1}{l_3}\right)U_3 - \frac{1}{l_3}U_4 = \frac{l_2 + l_3}{2}f_3$$

$$-\frac{1}{l_3}U_3 + \frac{1}{l_3}U_4 = \frac{l_3}{2}f_4$$

- **Homework 4**

1. Using the continuity requirements for beam problems (4<sup>th</sup>-order ODE) considered in homework 2, propose suitable interpolation (shape) functions for a beam element, and derive the element stiffness matrix of the beam element.
2. Derive a FDM equation for a cantilever beam subject to a concentrated load at the free end. Propose FDM equations for all boundary conditions for beam problems using proper ghost nodes. Discretize the beam with 5 nodes including two boundary nodes. Do not solve the system equations.

This page is intentionally left blank.

# Chapter 4

## Multidimensional Problems – Elasticity Problems –

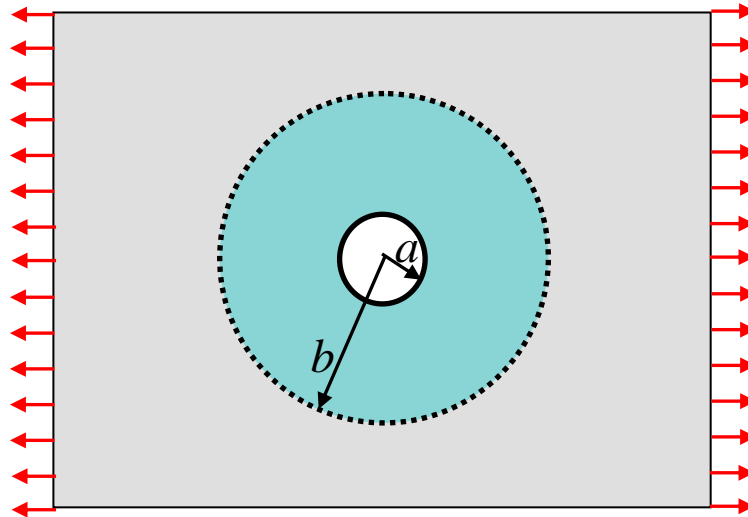

$$\begin{aligned}
 &= \frac{1}{2} \int_V \epsilon_{ij}^k \sigma_{ij}^k dV - \int_V u_i^k b_i dV - \int_r u_i^k \bar{T}_i d\Gamma \\
 &= \frac{1}{2} \int_V \frac{\partial(u_i - u_i^e)}{\partial x_j} D_{ijkl} \frac{\partial(u_k - u_k^e)}{\partial x_l} dV - \int_V (u_i - u_i^e) b_i dV - \int_r (u_i - u_i^e) \bar{T}_i d\Gamma \\
 &= \frac{1}{2} \int_V \frac{\partial u_i}{\partial x_j} D_{ijkl} \frac{\partial u_k}{\partial x_l} dV - \frac{1}{2} \int_V \frac{\partial u_i^e}{\partial x_j} D_{ijkl} \frac{\partial u_k^e}{\partial x_l} dV - \frac{1}{2} \int_V \frac{\partial u_i}{\partial x_j} D_{ijkl} \frac{\partial u_k^e}{\partial x_l} dV \\
 &\quad - \int_V (u_i - u_i^e) b_i dV - \int_r (u_i - u_i^e) \bar{T}_i d\Gamma \\
 &= \frac{1}{2} \int_V \frac{\partial u_i}{\partial x_j} D_{ijkl} \frac{\partial u_k}{\partial x_l} dV - \int_V u_i b_i dV - \int_r u_i \bar{T}_i d\Gamma + \frac{1}{2} \int_V \frac{\partial u_i^e}{\partial x_j} D_{ijkl} \frac{\partial u_k^e}{\partial x_l} dV \\
 &\quad - \left( \int_V \frac{\partial u_i^e}{\partial x_j} D_{ijkl} \frac{\partial u_k^e}{\partial x_l} dV - \int_V u_i^e b_i dV - \int_r u_i^e \bar{T}_i d\Gamma \right)
 \end{aligned}$$

#### 4.1. Problem Definition

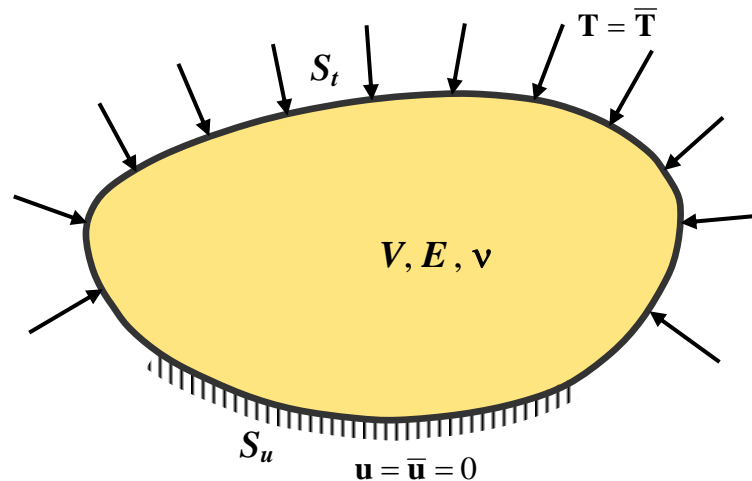

- **Governing Equations and Boundary Conditions**

Equilibrium Equation :  $\nabla \cdot \boldsymbol{\sigma} + \mathbf{b} = 0$  in  $V$

Constitutive Law :  $\boldsymbol{\sigma} = \mathbf{D} : \boldsymbol{\varepsilon}$  in  $V$

Strain-Displacement Relationship :  $\boldsymbol{\varepsilon} = \frac{1}{2}(\nabla \mathbf{u} + (\nabla \mathbf{u})^T)$  in  $V$

Displacement Boundary condition :  $\mathbf{u} - \bar{\mathbf{u}} = 0$  on  $S_u$

Traction Boundary Condition :  $\mathbf{T} - \bar{\mathbf{T}} = 0$  on  $S_t$

Cauchy's Relation on the Boundary :  $\mathbf{T} = \boldsymbol{\sigma} \cdot \mathbf{n}$  on  $S$

- **Strain Energy (Refer to pp. 244 - 246 of Theory of Elasticity by Timoshenko)**

$$\begin{aligned} \Pi_{\text{int}} &= \frac{1}{2} \int_V \boldsymbol{\varepsilon}_{ij} \boldsymbol{\sigma}_{ij} dV \leftarrow \boldsymbol{\varepsilon}_{ij} = \frac{1}{2} \left( \frac{\partial u_i}{\partial x_j} + \frac{\partial u_j}{\partial x_i} \right) \\ &= \frac{1}{2} \int_V \frac{1}{2} \left( \frac{\partial u_i}{\partial x_j} + \frac{\partial u_j}{\partial x_i} \right) \boldsymbol{\sigma}_{ij} dV \leftarrow \boldsymbol{\sigma}_{ij} = \boldsymbol{\sigma}_{ji} \\ &= \frac{1}{2} \int_V \frac{\partial u_i}{\partial x_j} \boldsymbol{\sigma}_{ij} dV \end{aligned}$$

- **Total Potential Energy**

$$\Pi = \frac{1}{2} \int_V \boldsymbol{\varepsilon}_{ij} \boldsymbol{\sigma}_{ij} dV - \int_V u_i b_i dV - \int_S u_i T_i dS$$

## 4.2. Error Minimization

- **Error Estimator** :  $\Pi^R = \frac{1}{2} \int_V (u_i - u_i^h)(\sigma_{ij,j}^h + b_i) dV + \frac{1}{2} \int_S (u_i - u_i^h)(T - T_i^h) dS$

- **Least Square Error**

$$\begin{aligned}
 \Pi^R &= \frac{1}{2} \int_V (u_i - u_i^h)(\sigma_{ij,j}^h - \sigma_{ij,j}) dV + \frac{1}{2} \int_S (u_i - u_i^h)(T - T_i^h) dS \\
 &= -\frac{1}{2} \int_V (u_{i,j} - u_{i,j}^h)(\sigma_{ij}^h - \sigma_{ij}) dV + \frac{1}{2} \int_S (u_i - u_i^h)(\sigma_{ij}^h - \sigma_{ij}) n_j dS + \frac{1}{2} \int_S (u_i - u_i^h)(T - T_i^h) dS \\
 &= \frac{1}{2} \int_V (u_{i,j} - u_{i,j}^h)(\sigma_{ij} - \sigma_{ij}^h) dV - \frac{1}{2} \int_S (u_i - u_i^h)(T - T_i^h) dS + \frac{1}{2} \int_S (u_i - u_i^h)(T - T_i^h) dS \\
 &= \frac{1}{2} \int_V (u_{i,j} - u_{i,j}^h)(\sigma_{ij} - \sigma_{ij}^h) dV \\
 &= \frac{1}{2} \int_V (u_{i,j} - u_{i,j}^h) D_{ijkl} (\varepsilon_{kl} - \varepsilon_{kl}^h) dV \\
 &= \frac{1}{2} \int_V (u_{i,j} - u_{i,j}^h) D_{ijkl} (u_{k,l} - u_{k,l}^h) dV = \Pi^{LS}
 \end{aligned}$$

- **Energy Functional – Total Potential Energy**

$$\begin{aligned}
 \Pi^{LS} &= \frac{1}{2} \int_V \left( \frac{\partial u_i}{\partial x_j} - \frac{\partial u_i^h}{\partial x_j} \right) (\sigma_{ij} - \sigma_{ij}^h) dV \\
 &= \frac{1}{2} \int_V \frac{\partial u_i}{\partial x_j} \sigma_{ij} dV - \frac{1}{2} \int_V \frac{\partial u_i}{\partial x_j} \sigma_{ij}^h dV - \frac{1}{2} \int_V \frac{\partial u_i^h}{\partial x_j} (\sigma_{ij} - \sigma_{ij}^h) dV \\
 &= \frac{1}{2} \int_V \frac{\partial u_i}{\partial x_j} \sigma_{ij} dV - \frac{1}{2} \int_V \frac{\partial u_i}{\partial x_j} D_{ijkl} \frac{\partial u_k^h}{\partial x_l} dV - \frac{1}{2} \int_V \frac{\partial u_i^h}{\partial x_j} (\sigma_{ij} - \sigma_{ij}^h) dV \\
 &= \frac{1}{2} \int_V \frac{\partial u_i}{\partial x_j} \sigma_{ij} dV - \frac{1}{2} \int_V \frac{\partial u_i^h}{\partial x_j} D_{ijkl} \frac{\partial u_k^h}{\partial x_l} dV - \frac{1}{2} \int_V \frac{\partial u_i^h}{\partial x_j} (\sigma_{ij} - \sigma_{ij}^h) dV \\
 &= \frac{1}{2} \int_V \frac{\partial u_i}{\partial x_j} \sigma_{ij} dV - \frac{1}{2} \int_V \frac{\partial u_i^h}{\partial x_j} \sigma_{ij}^h dV - \frac{1}{2} \int_V \frac{\partial u_i^h}{\partial x_j} (\sigma_{ij} - \sigma_{ij}^h) dV \\
 &= \frac{1}{2} \int_V \frac{\partial u_i}{\partial x_j} \sigma_{ij} dV + \frac{1}{2} \int_V \frac{\partial u_i^h}{\partial x_j} \sigma_{ij}^h dV - \int_V \frac{\partial u_i^h}{\partial x_j} \sigma_{ij} dV \\
 &= \frac{1}{2} \int_V \frac{\partial u_i}{\partial x_j} \sigma_{ij} dV + \frac{1}{2} \int_V \varepsilon_{ij}^h \sigma_{ij}^h dV + \int_V u_i^h \frac{\partial \sigma_{ij}}{\partial x_j} dV - \int_S u_i^h \sigma_{ij} n_j dS \\
 &= \frac{1}{2} \int_V \frac{\partial u_i}{\partial x_j} \sigma_{ij} dV + \frac{1}{2} \int_V \varepsilon_{ij}^h \sigma_{ij}^h dV - \int_V u_i^h b_i dV - \int_{S_i} u_i^h \bar{T}_i dS \\
 &= C + \Pi^{RR}
 \end{aligned}$$

- **Minimization Problems**

$$\text{Min } \Pi^R \Leftrightarrow \text{Min } \Pi^{LS} \Leftrightarrow \text{Min } \Pi^{RR} \text{ w.r.t. } u_i^h \in \mathfrak{U}^h$$

- $\text{Min } \Pi^{RR}$ : **Rayleigh-Ritz Method** or **Principle of Minimum Potential Energy**

Find  $\mathbf{u}^h \in \mathfrak{U}^h$  such that minimize  $\Pi^{RR}$

$$\text{where } \mathbf{u} \in \mathfrak{U} \equiv \{ \mathbf{u} \mid \mathbf{u} = 0 \text{ on } S_u, \left| \int_V \frac{du_i}{dx_j} D_{ijkl} \frac{du_k}{dx_l} dV \right| < \infty \}$$

- $\mathfrak{U}^h \equiv \mathfrak{U}$  : The exact solution.
- $\mathfrak{U}^h \subset \mathfrak{U}$  : An approximate solution.

- $\delta \Pi^{RR} = 0$ : **Variational Principle** or **Principle of Virtual Work**

$$\begin{aligned} \delta \Pi^{RR} &= \delta \left( \frac{1}{2} \int_V \varepsilon_{ij}^h \sigma_{ij}^h dV - \int_V u_i^h b_i dV - \int_{S_t} u_i^h \bar{T}_i dS \right) \\ &= \frac{1}{2} \int_V (\delta \varepsilon_{ij}^h \sigma_{ij}^h + \varepsilon_{ij}^h \delta \sigma_{ij}^h) dV - \int_V \delta u_i^h b_i dV - \int_{S_t} \delta u_i^h \bar{T}_i dS \\ &= \frac{1}{2} \int_V (\delta \varepsilon_{ij}^h D_{ijkl} \varepsilon_{kl}^h + \varepsilon_{ij}^h D_{ijkl} \delta \varepsilon_{kl}^h) dV - \int_V \delta u_i^h b_i dV - \int_{S_t} \delta u_i^h \bar{T}_i dS \\ &= \int_V \delta \varepsilon_{ij}^h D_{ijkl} \varepsilon_{kl}^h dV - \int_V \delta u_i^h b_i dV - \int_{S_t} \delta u_i^h \bar{T}_i dS \\ &= \int_V \delta \varepsilon_{ij}^h \sigma_{ij}^h dV - \int_V \delta u_i^h b_i dV - \int_{S_t} \delta u_i^h \bar{T}_i dS = 0 \end{aligned}$$

- **Absolute Minimum Property of the Total Potential Energy**

$$u_i^h = u_i - u_i^e$$

$$\begin{aligned} \Pi^h &= \frac{1}{2} \int_V \varepsilon_{ij}^h \sigma_{ij}^h dV - \int_V u_i^h b_i dV - \int_{S_t} u_i^h \bar{T}_i dS \\ &= \frac{1}{2} \int_V \frac{\partial(u_i - u_i^e)}{\partial x_j} D_{ijkl} \frac{\partial(u_k - u_k^e)}{\partial x_l} dV - \int_V (u_i - u_i^e) b_i dV - \int_{S_t} (u_i - u_i^e) \bar{T}_i dS \\ &= \frac{1}{2} \int_V \frac{\partial u_i}{\partial x_j} D_{ijkl} \frac{\partial u_k}{\partial x_l} dV - \frac{1}{2} \int_V \frac{\partial u_i^e}{\partial x_j} D_{ijkl} \frac{\partial u_k^e}{\partial x_l} dV - \frac{1}{2} \int_V \frac{\partial u_i}{\partial x_j} D_{ijkl} \frac{\partial u_k^e}{\partial x_l} dV \\ &\quad + \frac{1}{2} \int_V \frac{\partial u_i^e}{\partial x_j} D_{ijkl} \frac{\partial u_k^e}{\partial x_l} dV - \int_V (u_i - u_i^e) b_i dV - \int_{S_t} (u_i - u_i^e) \bar{T}_i dS \\ &= \frac{1}{2} \int_V \frac{\partial u_i}{\partial x_j} D_{ijkl} \frac{\partial u_k}{\partial x_l} dV - \int_V u_i b_i dV - \int_{S_t} u_i \bar{T}_i dS + \frac{1}{2} \int_V \frac{\partial u_i^e}{\partial x_j} D_{ijkl} \frac{\partial u_k^e}{\partial x_l} dV \\ &\quad - \left( \int_V \frac{\partial u_i^e}{\partial x_j} D_{ijkl} \frac{\partial u_k}{\partial x_l} dV - \int_V u_i^e b_i dV - \int_{S_t} u_i^e \bar{T}_i dS \right) \end{aligned}$$



$$\begin{aligned}
\Pi^h &= \Pi^E + \frac{1}{2} \int_V \frac{\partial u_i^e}{\partial x_j} D_{ijkl} \frac{\partial u_k^e}{\partial x_l} dV - \left( \int_V \frac{\partial u_i^e}{\partial x_j} \sigma_{ij} dV - \int_V u_i^e b_i dV - \int_{S_i} u_i^e \bar{T}_i dS \right) \\
&= \Pi^E + \frac{1}{2} \int_V \frac{\partial u_i^e}{\partial x_j} D_{ijkl} \frac{\partial u_k^e}{\partial x_l} dV - \left( - \int_V u_i^e \sigma_{ij,j} dV + \int_{\Gamma} u_i^e \sigma_{ij} n_j dS - \int_V u_i^e b_i dV - \int_{S_i} u_i^e \bar{T}_i dS \right) \\
&= \Pi^E + \frac{1}{2} \int_V \frac{\partial u_i^e}{\partial x_j} D_{ijkl} \frac{\partial u_k^e}{\partial x_l} dV - \left( - \int_V u_i^e \sigma_{ij,j} dV + \int_{S_i} u_i^e \bar{T}_i dS - \int_V u_i^e b_i dV - \int_{S_i} u_i^e \bar{T}_i dS \right) \\
&= \Pi^E + \frac{1}{2} \int_V \frac{\partial u_i^e}{\partial x_j} D_{ijkl} \frac{\partial u_k^e}{\partial x_l} dV + \left( \int_V u_i^e \sigma_{ij,j} dV + \int_V u_i^e b_i dV \right) \\
&= \Pi^E + \frac{1}{2} \int_V \frac{\partial u_i^e}{\partial x_j} D_{ijkl} \frac{\partial u_k^e}{\partial x_l} dV + \int_V u_i^e (\sigma_{ij,j} + b_i) dV \\
&= \Pi^E + \frac{1}{2} \int_V \frac{\partial u_i^e}{\partial x_j} D_{ijkl} \frac{\partial u_k^e}{\partial x_l} dV
\end{aligned}$$

Since  $D_{ijkl}$  is positive definite,  $\frac{\partial u_i^e}{\partial x_j} D_{ijkl} \frac{\partial u_k^e}{\partial x_l} > 0 \forall \frac{\partial u_i^e}{\partial x_j} \neq 0$  and

$$\int_V \frac{\partial u_i^e}{\partial x_j} D_{ijkl} \frac{\partial u_k^e}{\partial x_l} dV = 0 \text{ if and only if } \frac{\partial u_i^e}{\partial x_j} \equiv 0. \quad \text{Therefore}$$

$$\underline{\underline{\Pi^h \geq \Pi^E \quad (\text{The equality sign holds only for } u_i^h = u_i + ??.)}}$$

### 4.3. Principle of Virtual Work

If the following inequality is valid for all real number  $\alpha$ , the principle of virtual work holds.

$$\underline{\underline{\Pi^{RR}(u_i + \alpha v_i) \geq \Pi^{RR}(u_i) \quad \forall v_i \in \mathfrak{v}}}}$$

$$\begin{aligned}
g(\alpha) &\equiv \Pi^{RR}(u_i + \alpha v_i) \\
&= \frac{1}{2} \int_V \frac{\partial (u_i + \alpha v_i)}{\partial x_j} D_{ijkl} \frac{\partial (u_k + \alpha v_k)}{\partial x_l} dV - \int_V (u_i + \alpha v_i) b_i dV - \int_{S_i} (u_i + \alpha v_i) \bar{T}_i dS \\
&= \frac{1}{2} \int_V \frac{\partial u_i}{\partial x_j} D_{ijkl} \frac{\partial u_k}{\partial x_l} dV + \alpha \int_V \frac{\partial v_i}{\partial x_j} D_{ijkl} \frac{\partial u_k}{\partial x_l} dV + \frac{1}{2} \alpha^2 \int_V \frac{\partial v_i}{\partial x_j} D_{ijkl} \frac{\partial v_k}{\partial x_l} dV \\
&\quad - \int_V (u_i + \alpha v_i) b_i dV - \int_{S_i} (u_i + \alpha v_i) \bar{T}_i dS \\
g'(\alpha) &= \int_V \frac{\partial v_i}{\partial x_j} D_{ijkl} \frac{\partial u_k}{\partial x_l} dV - \int_V v_i b_i dV - \int_{S_i} v_i \bar{T}_i dS + \alpha \int_V \frac{\partial v_i}{\partial x_j} D_{ijkl} \frac{\partial v_k}{\partial x_l} dV \\
g'(0) &= \int_V \frac{\partial v_i}{\partial x_j} D_{ijkl} \frac{\partial u_k}{\partial x_l} dV - \int_V v_i b_i dV - \int_{S_i} v_i \bar{T}_i dS = 0 \quad \forall v_i \in \mathfrak{v} \text{ (for all admissible } v_i \text{)}
\end{aligned}$$

If the principle of virtual work holds, then the principle of minimum potential energy holds because the boxed equation of the total potential energy vanishes identically. The approximate version of the principle of virtual work is

$$\underline{\underline{\int_V \frac{\partial v_i^h}{\partial x_j} \sigma_{ij}^h dV - \int_V v_i^h b_i dV - \int_{S_i} v_i^h \bar{T}_i dS = 0 \quad \text{for all admissible } v_i^h}}$$

- **Equivalence to the PDE**

- *Exact form*

$$\int_V v_i (\sigma_{ij,j} + b_i) dV - \int_{S_i} v_i (T_i - \bar{T}_i) dS = 0 \quad \forall v_i \in \mathcal{U} \rightarrow \underline{\underline{\sigma_{ij,j} + b_i = 0, T_i = \bar{T}_i}}$$

- *Approximate form*

$$\int_V v_i^h (\sigma_{ij,j}^h + b_i) dV - \int_{S_i} v_i^h (T_i^h - \bar{T}_i) dS = 0 \quad \forall v_i^h \in \mathcal{U}^h \rightarrow \underline{\underline{\sigma_{ij,j} + b_i \neq 0, T_i \neq \bar{T}_i}}$$

$$\text{Since } \int_V v_i (\sigma_{ij,j}^h + b_i) dV - \int_{S_i} v_i (T_i^h - \bar{T}_i) dS \neq 0 \quad \forall v_i \in \mathcal{U} .$$

- **Equivalence to the Weighted Residual Method**

- *Discretization* :  $v_i^h = \delta a_{ik} g_k$  ,  $u_i^h = a_{ik} g_k$

$$\int_V \delta a_{ik} g_k (\sigma_{ij,j}^h + b_i) dV = \int_{S_i} \delta a_{ik} g_k (T_i^h - \bar{T}_i) dS \quad \text{for possible } \delta a_{ik} \rightarrow$$

$$\int_V g_k (\sigma_{ij,j}^h + b_i) dV = \int_{S_i} g_k (T_i^h - \bar{T}_i) dS \quad \text{for all } k$$

- **Uniqueness of solution**

If two solutions satisfy the principle of virtual work, then

$$\int_V \frac{\partial v_i}{\partial x_j} \sigma_{ij}^1 dV - \int_V v_i b_i dV - \int_{S_i} v_i \bar{T}_i dS = 0 \quad \text{for all admissible } v_i$$

$$\int_V \frac{\partial v_i}{\partial x_j} \sigma_{ij}^2 dV - \int_V v_i b_i dV - \int_{S_i} v_i \bar{T}_i dS = 0 \quad \text{for all admissible } v_i$$

By subtracting two equations,

$$\int_V \frac{\partial v_i}{\partial x_j} (\sigma_{ij}^1 - \sigma_{ij}^2) dV = 0 \quad \text{for all admissible } v_i \rightarrow \sigma_{ij}^1 - \sigma_{ij}^2 = 0$$

$$\underline{\underline{D_{ijkl} \left( \frac{\partial u_k^1}{\partial x_l} - \frac{\partial u_k^2}{\partial x_l} \right) = 0 \rightarrow \frac{\partial u_k^1}{\partial x_l} - \frac{\partial u_k^2}{\partial x_l} = 0}}$$

# Chapter 5

## Discretization

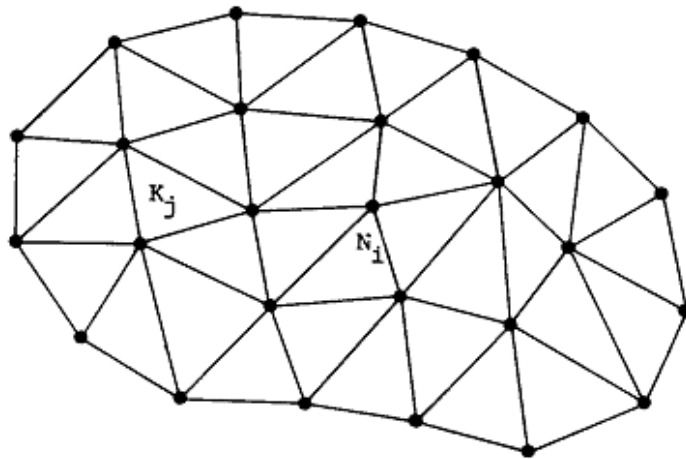

5.1. Rayleigh-Ritz Type Discretization

5.2. Finite Element Discretization

5.3. Finite Element Programming (Linear static case)

## 5.1. Rayleigh-Ritz Type Discretization

- **Approximation**

$$u_i^h = c_{i1}g_1 + c_{i2}g_2 + \cdots + c_{in}g_n = \sum_{p=1}^n c_{ip}g_p$$

$$\frac{\partial u_i^h}{\partial x_j} = \sum_{p=1}^n c_{ip} \frac{\partial g_p}{\partial x_j} = c_{ip} \frac{\partial g_p}{\partial x_j}$$

- **Principle of Minimum Potential Energy**

$$\text{Min } \Pi^h = \frac{1}{2} \int_V c_{ip} \frac{\partial g_p}{\partial x_j} D_{ijkl} c_{kq} \frac{\partial g_q}{\partial x_l} dV - \int_V c_{ip} g_p b_i dV - \int_{S_i} c_{ip} g_p \bar{T}_i dS \quad \text{or} \quad \frac{\partial \Pi^h}{\partial c_{mr}} = 0 \quad \text{for all } m, r$$

$$\begin{aligned} \frac{\partial \Pi^h}{\partial c_{mr}} &= \frac{1}{2} \int_V \delta_{mi} \delta_{rp} \frac{\partial g_p}{\partial x_j} D_{ijkl} c_{kq} \frac{\partial g_q}{\partial x_l} dV + \frac{1}{2} \int_V c_{ip} \frac{\partial g_p}{\partial x_j} D_{ijkl} \delta_{mk} \delta_{rq} \frac{\partial g_q}{\partial x_l} dV \\ &\quad - \int_V \delta_{mi} g_r b_i dV - \int_{S_i} \delta_{mi} g_r \bar{T}_i dS \\ &= \frac{1}{2} \int_V \frac{\partial g_r}{\partial x_j} D_{mjkl} c_{kq} \frac{\partial g_q}{\partial x_l} dV + \frac{1}{2} \int_V c_{ip} \frac{\partial g_p}{\partial x_j} D_{ijml} \frac{\partial g_r}{\partial x_l} dV - \int_V g_r b_m dV - \int_{S_i} g_r \bar{T}_m dS \\ &= \int_V \frac{\partial g_r}{\partial x_j} D_{mjkl} c_{kp} \frac{\partial g_p}{\partial x_l} dV - \int_V g_r b_m dV - \int_{S_i} g_r \bar{T}_m dS \\ &= \int_V \frac{\partial g_r}{\partial x_j} D_{mjkl} \frac{\partial g_p}{\partial x_l} dV c_{kp} - \int_V g_r b_m dV - \int_{S_i} g_r \bar{T}_m dS \\ &= K_{rmkp} c_{kp} - f_{rm} = 0 \quad \text{for all } r \text{ and } m \end{aligned}$$

- **Principle of Virtual Work**

$$\begin{aligned} \int_V \delta \varepsilon_{ij}^h \sigma_{ij}^h dV - \int_V \delta u_i^h b_i^h dV - \int_V \delta u_i^h \bar{T}_i dV &= 0 \\ \delta \Pi^h &= \int_V \delta c_{ip} \frac{\partial g_p}{\partial x_j} D_{ijkl} c_{kq} \frac{\partial g_q}{\partial x_l} dV - \int_V \delta c_{ip} g_p b_i dV - \int_{S_i} \delta c_{ip} g_p \bar{T}_i dS \\ &= \delta c_{ip} \left( \int_V \frac{\partial g_p}{\partial x_j} D_{ijkl} \frac{\partial g_q}{\partial x_l} dV c_{kq} - \int_V g_p b_i dV - \int_{S_i} g_p \bar{T}_i dS \right) \\ &= \delta c_{ip} \left( \int_V \frac{\partial g_p}{\partial x_j} D_{ijkl} \frac{\partial g_q}{\partial x_l} dV c_{kq} - \int_V g_p b_i dV - \int_{S_i} g_p \bar{T}_i dS \right) = 0 \quad \text{for all } \delta c_{ip} \end{aligned}$$

$$K_{pikq} c_{kq} - f_{pi} = 0 \quad \text{for all } p \text{ and } i$$

- Matrix Form – Virtual Work Expression

$$\begin{aligned}
 & \int_V \delta \varepsilon_{ij}^h \sigma_{ij}^h dV \\
 &= \int_V (\delta \varepsilon_{11}^h \sigma_{11}^h + \delta \varepsilon_{22}^h \sigma_{22}^h + \delta \varepsilon_{33}^h \sigma_{33}^h + \delta \varepsilon_{12}^h \sigma_{12}^h + \delta \varepsilon_{21}^h \sigma_{21}^h + \delta \varepsilon_{13}^h \sigma_{13}^h + \delta \varepsilon_{31}^h \sigma_{31}^h + \delta \varepsilon_{23}^h \sigma_{23}^h + \delta \varepsilon_{32}^h \sigma_{32}^h) dV \\
 &= \int_V (\delta \varepsilon_{11}^h \sigma_{11}^h + \delta \varepsilon_{22}^h \sigma_{22}^h + \delta \varepsilon_{33}^h \sigma_{33}^h + 2\delta \varepsilon_{12}^h \sigma_{12}^h + 2\delta \varepsilon_{13}^h \sigma_{13}^h + 2\delta \varepsilon_{23}^h \sigma_{23}^h) dV \\
 &= \int_V (\delta \varepsilon_{11}^h \sigma_{11}^h + \delta \varepsilon_{22}^h \sigma_{22}^h + \delta \varepsilon_{33}^h \sigma_{33}^h + \delta \gamma_{12}^h \sigma_{12}^h + \delta \gamma_{13}^h \sigma_{13}^h + \delta \gamma_{23}^h \sigma_{23}^h) dV = \int_V \delta \boldsymbol{\varepsilon}^h \cdot \boldsymbol{\sigma}^h dV
 \end{aligned}$$

$$\underline{\underline{\int_V \delta \boldsymbol{\varepsilon}^h \cdot \boldsymbol{\sigma}^h dV = \int_V \delta \mathbf{u}^h \cdot \mathbf{b} dV + \int_{S_i} \delta \mathbf{u}^h \cdot \bar{\mathbf{T}} dS}}$$

- Displacement

$$\mathbf{u}^h = \begin{pmatrix} u_1^h \\ u_2^h \\ u_3^h \end{pmatrix} = \begin{bmatrix} g_1 & 0 & 0 & g_2 & 0 & 0 & g_n & 0 & 0 \\ 0 & g_1 & 0 & 0 & g_2 & 0 & \dots & 0 & g_n & 0 \\ 0 & 0 & g_1 & 0 & 0 & g_2 & 0 & 0 & 0 & g_n \end{bmatrix} \begin{pmatrix} c_{11} \\ c_{21} \\ c_{31} \\ c_{12} \\ c_{22} \\ c_{32} \\ \vdots \\ c_{1n} \\ c_{2n} \\ c_{3n} \end{pmatrix} = \mathbf{Nc}$$

- Virtual Strain

$$(\delta \boldsymbol{\varepsilon}^h) = \begin{pmatrix} \delta \varepsilon_{11}^h \\ \delta \varepsilon_{22}^h \\ \delta \varepsilon_{33}^h \\ \delta \gamma_{12}^h \\ \delta \gamma_{13}^h \\ \delta \gamma_{23}^h \end{pmatrix} = \begin{pmatrix} \frac{\partial \delta u_1^h}{\partial x_1} \\ \frac{\partial \delta u_2^h}{\partial x_2} \\ \frac{\partial \delta u_3^h}{\partial x_3} \\ \frac{\partial \delta u_1^h}{\partial x_2} + \frac{\partial \delta u_2^h}{\partial x_1} \\ \frac{\partial \delta u_1^h}{\partial x_3} + \frac{\partial \delta u_3^h}{\partial x_1} \\ \frac{\partial \delta u_2^h}{\partial x_3} + \frac{\partial \delta u_3^h}{\partial x_2} \end{pmatrix} = \begin{pmatrix} \delta c_{1i} \frac{\partial g_i}{\partial x_1} \\ \delta c_{2i} \frac{\partial g_i}{\partial x_2} \\ \delta c_{3i} \frac{\partial g_i}{\partial x_3} \\ \delta c_{1i} \frac{\partial g_i}{\partial x_2} + \delta c_{2i} \frac{\partial g_i}{\partial x_1} \\ \delta c_{1i} \frac{\partial g_i}{\partial x_3} + \delta c_{3i} \frac{\partial g_i}{\partial x_1} \\ \delta c_{2i} \frac{\partial g_i}{\partial x_3} + \delta c_{3i} \frac{\partial g_i}{\partial x_2} \end{pmatrix}$$

- **Virtual Strain - Matrix Form**

$$(\delta \boldsymbol{\varepsilon}^h) = \begin{pmatrix} \delta \varepsilon_{11}^h \\ \delta \varepsilon_{22}^h \\ \delta \varepsilon_{33}^h \\ \delta \gamma_{12}^h \\ \delta \gamma_{13}^h \\ \delta \gamma_{23}^h \end{pmatrix} = \begin{bmatrix} \frac{\partial g_1}{\partial x_1} & 0 & 0 & \frac{\partial g_2}{\partial x_1} & 0 & 0 & \frac{\partial g_n}{\partial x_1} & 0 & 0 \\ 0 & \frac{\partial g_1}{\partial x_2} & 0 & 0 & \frac{\partial g_2}{\partial x_2} & 0 & 0 & \frac{\partial g_n}{\partial x_2} & 0 \\ 0 & 0 & \frac{\partial g_1}{\partial x_3} & 0 & 0 & \frac{\partial g_2}{\partial x_3} & 0 & 0 & \frac{\partial g_n}{\partial x_3} \\ \frac{\partial g_1}{\partial x_2} & \frac{\partial g_1}{\partial x_1} & 0 & \frac{\partial g_2}{\partial x_2} & \frac{\partial g_2}{\partial x_1} & 0 & \dots & \frac{\partial g_n}{\partial x_2} & \frac{\partial g_n}{\partial x_1} & 0 \\ \frac{\partial g_1}{\partial x_3} & 0 & \frac{\partial g_1}{\partial x_1} & \frac{\partial g_2}{\partial x_3} & 0 & \frac{\partial g_2}{\partial x_1} & \dots & \frac{\partial g_n}{\partial x_3} & 0 & \frac{\partial g_n}{\partial x_1} \\ 0 & \frac{\partial g_1}{\partial x_3} & \frac{\partial g_1}{\partial x_2} & 0 & \frac{\partial g_2}{\partial x_3} & \frac{\partial g_2}{\partial x_2} & \dots & 0 & \frac{\partial g_n}{\partial x_3} & \frac{\partial g_n}{\partial x_2} \end{bmatrix} \begin{pmatrix} \delta c_{11} \\ \delta c_{21} \\ \delta c_{31} \\ \delta c_{12} \\ \delta c_{22} \\ \delta c_{32} \\ \vdots \\ \delta c_{1n} \\ \delta c_{2n} \\ \delta c_{3n} \end{pmatrix} \\
 = \mathbf{B} \delta \mathbf{c}$$

- **Stress-strain (displacement) Relation**

$$(\boldsymbol{\sigma}^h) = \begin{pmatrix} \sigma_{11}^h \\ \sigma_{22}^h \\ \sigma_{33}^h \\ \sigma_{12}^h \\ \sigma_{13}^h \\ \sigma_{23}^h \end{pmatrix} = \frac{E(1-\nu)}{(1+\nu)(1-2\nu)} \begin{bmatrix} 1 & \frac{\nu}{1-\nu} & \frac{\nu}{1-\nu} & 0 & 0 & 0 \\ \frac{\nu}{1-\nu} & 1 & \frac{\nu}{1-\nu} & 0 & 0 & 0 \\ \frac{\nu}{1-\nu} & \frac{\nu}{1-\nu} & 1 & 0 & 0 & 0 \\ 0 & 0 & 0 & \frac{1-2\nu}{2(1-\nu)} & 0 & 0 \\ 0 & 0 & 0 & 0 & \frac{1-2\nu}{2(1-\nu)} & 0 \\ 0 & 0 & 0 & 0 & 0 & \frac{1-2\nu}{2(1-\nu)} \end{bmatrix} \begin{pmatrix} \varepsilon_{11}^h \\ \varepsilon_{22}^h \\ \varepsilon_{33}^h \\ \gamma_{12}^h \\ \gamma_{13}^h \\ \gamma_{23}^h \end{pmatrix} \\
 = \mathbf{D} \boldsymbol{\varepsilon}^h = \mathbf{D} \mathbf{B} \mathbf{c}$$

- **Final System Equation**

$$\int_V \delta \varepsilon_{ij}^h \sigma_{ij}^h dV = \int_V \delta \boldsymbol{\varepsilon}^{hT} \boldsymbol{\sigma}^h dV = \delta \mathbf{c}^T \int_V \mathbf{B}^T \mathbf{D} \mathbf{B} dV \mathbf{c}$$

$$\int_V \delta u_i^h b_i dV = \int_V \delta \mathbf{u}^{hT} \mathbf{b} dV = \delta \mathbf{c}^T \int_V \mathbf{N}^T \mathbf{b} dV$$

$$\int_{S_i} \delta u_i^h T_i dS = \int_{S_i} \delta \mathbf{u}^{hT} \bar{\mathbf{T}} dS = \delta \mathbf{c}^T \int_{S_i} \mathbf{N}^T \bar{\mathbf{T}} dS$$

$$\delta \mathbf{c}^T \left( \int_V \mathbf{B}^T \mathbf{D} \mathbf{B} dV \mathbf{c} - \int_V \mathbf{N}^T \mathbf{b} dV - \int_{S_i} \mathbf{N}^T \bar{\mathbf{T}} dS \right) = 0 \quad \text{for all admissible } \delta \mathbf{c} \text{ or } \mathbf{K} \mathbf{c} = \mathbf{f}$$

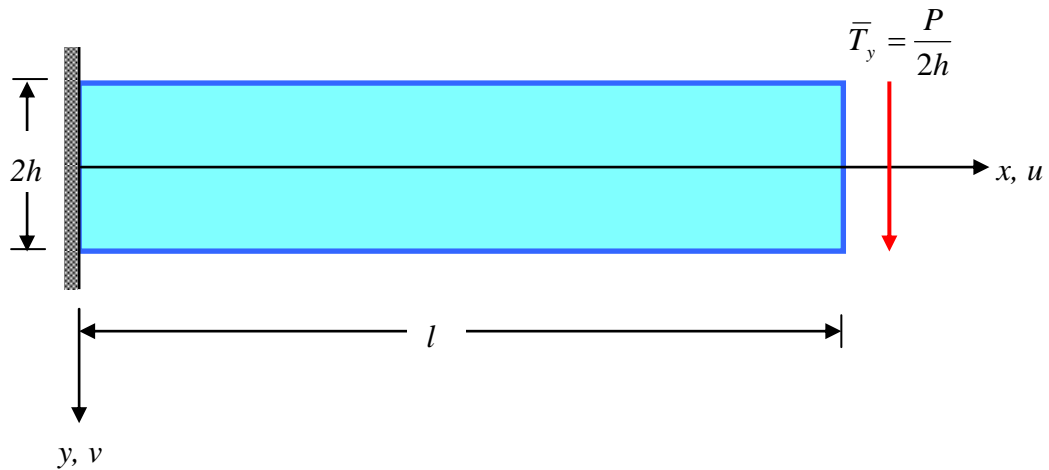
**Example**

- Displacement Field**

By the elementary beam solution, the displacement field of the structure is assumed as

$$u = a\left(\frac{x^2}{2} - lx\right)y$$

$$v = b\left(\frac{x^3}{6} - \frac{x^2}{2}l\right)$$

$$\mathbf{N} = \begin{bmatrix} \left(\frac{x^2}{2} - lx\right)y & 0 \\ 0 & \frac{x^3}{6} - \frac{x^2}{2}l \end{bmatrix}, \quad \mathbf{B} = \begin{bmatrix} (x-l)y & 0 \\ 0 & 0 \\ \frac{x^2}{2} - lx & \frac{x^2}{2} - lx \end{bmatrix}, \quad \mathbf{D} = \frac{E}{1-\nu^2} \begin{bmatrix} 1 & \nu & 0 \\ \nu & 1 & 0 \\ 0 & 0 & \frac{1-\nu}{2} \end{bmatrix}$$

- Stiffness Matrix**

$$\mathbf{K} = \frac{E}{1-\nu^2} \int_0^l \int_{-h}^h \int_0^1 \begin{bmatrix} (x-l)y & 0 & \frac{x^2}{2} - lx \\ 0 & 0 & \frac{x^2}{2} - lx \end{bmatrix} \begin{bmatrix} 1 & \nu & 0 \\ \nu & 1 & 0 \\ 0 & 0 & \frac{1-\nu}{2} \end{bmatrix} \begin{bmatrix} (x-l)y & 0 \\ 0 & 0 \\ \frac{x^2}{2} - lx & \frac{x^2}{2} - lx \end{bmatrix} dz dy dx$$

$$= \frac{E}{1-\nu^2} \int_0^l \int_{-h}^h \begin{bmatrix} (x-l)^2 y^2 + \frac{1-\nu}{2} \left(\frac{x^2}{2} - lx\right)^2 & \frac{1-\nu}{2} \left(\frac{x^2}{2} - lx\right)^2 \\ \frac{1-\nu}{2} \left(\frac{x^2}{2} - lx\right)^2 & \frac{1-\nu}{2} \left(\frac{x^2}{2} - lx\right)^2 \end{bmatrix} dz dy dx$$

$$= \frac{E}{1-\nu^2} \begin{bmatrix} 2\frac{l^3}{3} \frac{h^3}{3} + \frac{1-\nu}{2} \frac{2}{15} l^5 (2h) & \frac{1-\nu}{2} \frac{2}{15} l^5 (2h) \\ \frac{1-\nu}{2} \frac{2}{15} l^5 (2h) & \frac{1-\nu}{2} \frac{2}{15} l^5 (2h) \end{bmatrix}$$

- **Load Term**

$$\mathbf{f} = \int_{-h}^h \int_0^l \begin{bmatrix} -\frac{l^2}{2} - y & 0 \\ 0 & -\frac{l^3}{3} \end{bmatrix} \begin{pmatrix} 0 \\ P \\ 2h \end{pmatrix} dx dy = -\frac{l^3}{3} \begin{pmatrix} 0 \\ P \end{pmatrix}$$

- **System Equation**

$$\frac{E}{1-\nu^2} \begin{bmatrix} 2\frac{l^3}{3}\frac{h^3}{3} + \frac{1-\nu}{2}\frac{2}{15}l^5(2h) & \frac{1-\nu}{2}\frac{2}{15}l^5(2h) \\ \frac{1-\nu}{2}\frac{2}{15}l^5(2h) & \frac{1-\nu}{2}\frac{2}{15}l^5(2h) \end{bmatrix} \begin{pmatrix} a \\ b \end{pmatrix} = -\frac{l^3}{3} \begin{pmatrix} 0 \\ P \end{pmatrix}$$

$$a = \frac{3}{2} \frac{1-\nu^2}{Eh^3} P = \frac{1-\nu^2}{EI} P, \quad b = -\left(1 + \frac{5}{3} \frac{1}{1-\nu} \left(\frac{h}{l}\right)^2\right) \frac{1-\nu^2}{EI} P$$

- **Displacement and Stress**

$$u = \frac{1-\nu^2}{EI} P \left( \frac{x^2}{2} - lx \right) y$$

$$v = -\left(1 + \frac{5}{3} \frac{1}{1-\nu} \left(\frac{h}{l}\right)^2\right) \frac{1-\nu^2}{EI} P \left( \frac{x^3}{6} - \frac{x^2}{2} l \right)$$

$$\sigma_{xx} = \frac{P(x-l)}{I} y = \frac{M}{I} y$$

$$\sigma_{yy} = \nu \frac{M}{I} y$$

$$\tau_{xy} = -\frac{5}{6} \left(\frac{h}{l}\right)^2 \frac{1}{I} \left( \frac{x^2}{2} - xl \right) P$$



### Home Work 5

1. The displacement field of a thin plate is expressed as follows.

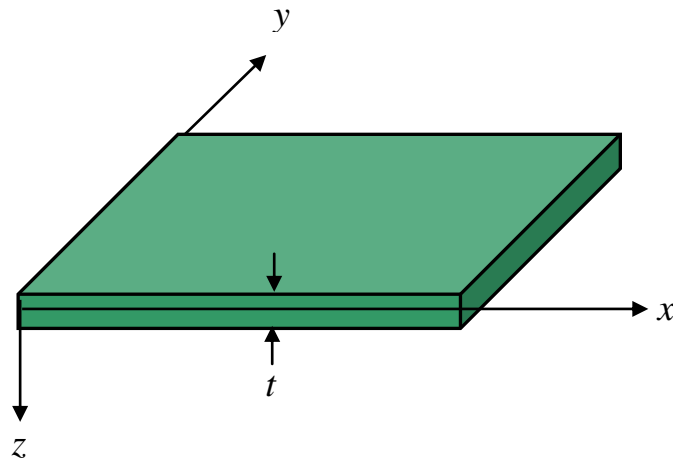

$$u(x, y, z) = -\frac{\partial w}{\partial x} z, \quad v(x, y, z) = -\frac{\partial w}{\partial y} z, \quad w = w(x, y)$$

- 1) Drive the strain component using the given displacement field.
- 2) Assume  $\sigma_{33} = 0$ , and the plate is under plane stress condition, drive stress components.
- 3) Drive expressions for the total potential energy and the virtual work in case the plate is subject to a traverse load  $a$  on the upper surface. (hint: perform analytic integration in the direction of the thickness)
- 4) Drive the governing equation and all possible boundary conditions on the four edges.

2. Analyze the structure shown in the following figure under the plane stress condition by Rayleigh-Ritz method

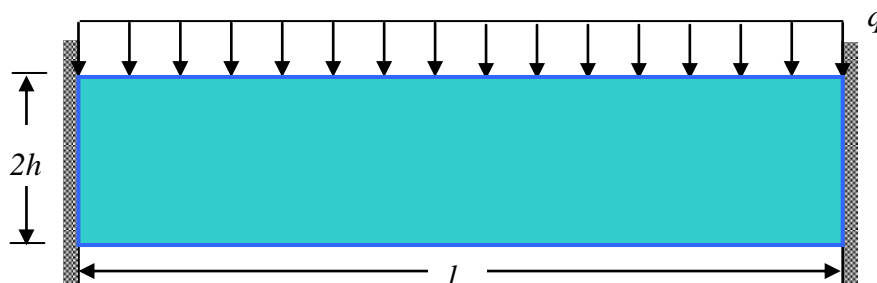

## 5.2. Finite Element Discretization

- Domain Discretization

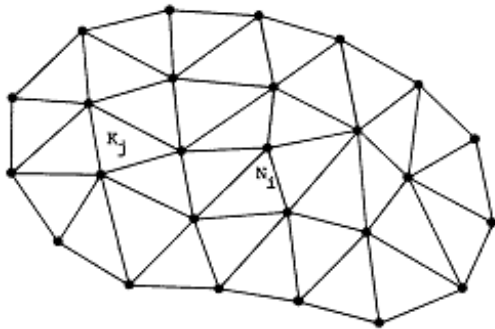

$$V = V^1 \cup V^2 \cup \dots \cup V^n, \quad \Gamma = \Gamma^1 \cup \Gamma^2 \cup \dots \cup \Gamma^m$$

$$\int_V \delta \boldsymbol{\epsilon}^{hT} \boldsymbol{\sigma}^h dV = \int_V \delta \mathbf{u}^{hT} \mathbf{b} dV + \int_{\Gamma_i} \delta \mathbf{u}^{hT} \bar{\mathbf{T}} d\Gamma$$

$$\sum_e \int_{V^e} \delta \boldsymbol{\epsilon}^{hT} \boldsymbol{\sigma}^h dV = \sum_e \int_{V^e} \delta \mathbf{u}^{hT} \mathbf{b} dV + \sum_e \int_{S_i^e} \delta \mathbf{u}^{hT} \mathbf{b} dS$$

- The displacement field in an element

$$\mathbf{u}^e = \begin{pmatrix} u_1^e \\ u_2^e \\ u_3^e \end{pmatrix} = \begin{bmatrix} N_1 & 0 & 0 & N_2 & 0 & 0 & \dots & N_n & 0 & 0 \\ 0 & N_1 & 0 & 0 & N_2 & 0 & \dots & 0 & N_n & 0 \\ 0 & 0 & N_1 & 0 & 0 & N_2 & 0 & 0 & 0 & N_n \end{bmatrix} \begin{pmatrix} u_{11} \\ u_{21} \\ u_{31} \\ u_{12} \\ u_{22} \\ u_{32} \\ \vdots \\ u_{1n} \\ u_{2n} \\ u_{3n} \end{pmatrix} = \mathbf{N}^e \mathbf{U}^e$$

where  $N_i(\mathbf{X}_j) = \delta_{ij}$ .

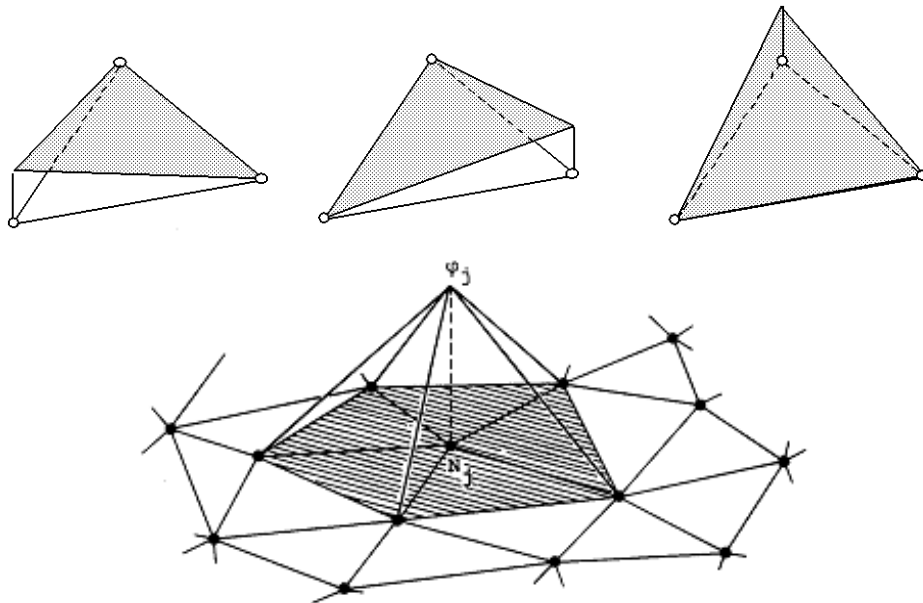

- **The virtual strain field in an element**

$$\delta \boldsymbol{\varepsilon}^e = \begin{pmatrix} \delta \varepsilon_{11}^e \\ \delta \varepsilon_{22}^e \\ \delta \varepsilon_{33}^e \\ \delta \gamma_{12}^e \\ \delta \gamma_{13}^e \\ \delta \gamma_{23}^e \end{pmatrix} = \begin{pmatrix} \frac{\partial \delta u_1^e}{\partial x_1} \\ \frac{\partial \delta u_2^e}{\partial x_2} \\ \frac{\partial \delta u_3^e}{\partial x_3} \\ \frac{\partial \delta u_1^e}{\partial x_2} + \frac{\partial \delta u_2^e}{\partial x_1} \\ \frac{\partial \delta u_1^e}{\partial x_3} + \frac{\partial \delta u_3^e}{\partial x_1} \\ \frac{\partial \delta u_2^e}{\partial x_3} + \frac{\partial \delta u_3^e}{\partial x_2} \end{pmatrix} = \begin{pmatrix} \delta u_{1i} \frac{\partial N_i}{\partial x_1} \\ \delta u_{2i} \frac{\partial N_i}{\partial x_2} \\ \delta u_{3i} \frac{\partial N_i}{\partial x_3} \\ \delta u_{1i} \frac{\partial N_i}{\partial x_2} + \delta u_{2i} \frac{\partial N_i}{\partial x_1} \\ \delta u_{1i} \frac{\partial N_i}{\partial x_3} + \delta u_{3i} \frac{\partial N_i}{\partial x_1} \\ \delta u_{2i} \frac{\partial N_i}{\partial x_3} + \delta u_{3i} \frac{\partial N_i}{\partial x_2} \end{pmatrix}$$

$$= \begin{bmatrix} \frac{\partial N_1}{\partial x_1} & 0 & 0 & \frac{\partial N_2}{\partial x_1} & 0 & 0 & \frac{\partial N_n}{\partial x_1} & 0 & 0 \\ 0 & \frac{\partial N_1}{\partial x_2} & 0 & 0 & \frac{\partial N_2}{\partial x_2} & 0 & 0 & \frac{\partial N_n}{\partial x_2} & 0 \\ 0 & 0 & \frac{\partial N_1}{\partial x_3} & 0 & 0 & \frac{\partial N_2}{\partial x_3} & 0 & 0 & \frac{\partial N_n}{\partial x_3} \\ \frac{\partial N_1}{\partial x_2} & \frac{\partial N_1}{\partial x_1} & 0 & \frac{\partial N_2}{\partial x_2} & \frac{\partial N_2}{\partial x_1} & 0 & \dots & \frac{\partial N_n}{\partial x_2} & \frac{\partial N_n}{\partial x_1} & 0 \\ \frac{\partial N_1}{\partial x_3} & 0 & \frac{\partial N_1}{\partial x_1} & \frac{\partial N_2}{\partial x_3} & 0 & \frac{\partial N_2}{\partial x_1} & \frac{\partial N_n}{\partial x_3} & 0 & \frac{\partial N_n}{\partial x_1} & \frac{\partial N_n}{\partial x_3} \\ 0 & \frac{\partial N_1}{\partial x_3} & \frac{\partial N_1}{\partial x_2} & 0 & \frac{\partial N_2}{\partial x_3} & \frac{\partial N_2}{\partial x_2} & 0 & \frac{\partial N_n}{\partial x_3} & \frac{\partial N_n}{\partial x_2} & \frac{\partial N_n}{\partial x_2} \end{bmatrix} \begin{pmatrix} \delta u_{11} \\ \delta u_{21} \\ \delta u_{31} \\ \delta u_{12} \\ \delta u_{22} \\ \delta u_{32} \\ \vdots \\ \delta u_{1n} \\ \delta u_{2n} \\ \delta u_{3n} \end{pmatrix}^e = \mathbf{B} \delta \mathbf{U}^e$$

- **The stress field in an element**

$$\boldsymbol{\sigma}^e = \begin{pmatrix} \sigma_{11}^e \\ \sigma_{22}^e \\ \sigma_{33}^e \\ \sigma_{12}^e \\ \sigma_{13}^e \\ \sigma_{23}^e \end{pmatrix} = \frac{E(1-\nu)}{(1+\nu)(1-2\nu)} \begin{bmatrix} 1 & \frac{\nu}{1-\nu} & \frac{\nu}{1-\nu} & 0 & 0 & 0 \\ \frac{\nu}{1-\nu} & 1 & \frac{\nu}{1-\nu} & 0 & 0 & 0 \\ \frac{\nu}{1-\nu} & \frac{\nu}{1-\nu} & 1 & 0 & 0 & 0 \\ 0 & 0 & 0 & \frac{1-2\nu}{2(1-\nu)} & 0 & 0 \\ 0 & 0 & 0 & 0 & \frac{1-2\nu}{2(1-\nu)} & 0 \\ 0 & 0 & 0 & 0 & 0 & \frac{1-2\nu}{2(1-\nu)} \end{bmatrix} \begin{pmatrix} \varepsilon_{11}^e \\ \varepsilon_{22}^e \\ \varepsilon_{33}^e \\ \gamma_{12}^e \\ \gamma_{13}^e \\ \gamma_{23}^e \end{pmatrix}$$

$$= \mathbf{D} \boldsymbol{\varepsilon}^e = \mathbf{D} \mathbf{B} \mathbf{U}^e$$

- **Stiffness Equation**

$$\sum_e \delta \mathbf{U}^{eT} \int_{V^e} \mathbf{B}^T \mathbf{D} \mathbf{B} dV \mathbf{U}^e - \sum_e \delta \mathbf{U}^{eT} \int_{V^e} \mathbf{N}^T \mathbf{b} dV - \sum_e \delta \mathbf{U}^{eT} \int_{S_i^e} \mathbf{N}^T \bar{\mathbf{T}} dS = 0$$

$$\sum_e \delta \mathbf{U}^{eT} \mathbf{K}^e \mathbf{U}^e - \sum_e \delta \mathbf{U}^{eT} \mathbf{f}^e = 0$$

- **Compatibility Conditions**

$$\mathbf{U}^e = \mathbf{T}^e \mathbf{U} \quad , \quad \delta \mathbf{U}^e = \mathbf{T}^e \delta \mathbf{U}$$

$$\delta \mathbf{U}^T \sum_e \mathbf{T}^{eT} \mathbf{K}^e \mathbf{T}^e \mathbf{U} - \delta \mathbf{U}^T \sum_e \mathbf{T}^{eT} \mathbf{f}^e = 0 \text{ for all admissible } \delta \mathbf{U}$$

$$\mathbf{K} \mathbf{U} - \mathbf{f} = \mathbf{0}$$

- **Finite Element Procedure**

1. Governing equations in the domain, boundary conditions on the boundary.
2. Derive weak form of the G.E. and B.C. by the variational principle or equivalent.
3. Discretize the given domain and boundary with finite elements.

$$V = V^1 \cup V^2 \cup \dots \cup V^n \quad , \quad S = S^1 \cup S^2 \cup \dots \cup S^n$$

4. Assume the displacement field by shape functions and nodal values within an element.

$$\mathbf{u}^e = \mathbf{N}^e \mathbf{U}^e$$

5. Calculate the element stiffness matrix and assemble it according to the computability.

$$\mathbf{K}^e = \int_{V^e} \mathbf{B}^T \mathbf{D} \mathbf{B} dV \quad , \quad \mathbf{K} = \sum_e \mathbf{K}^e$$

6. Calculate the equivalent nodal force and assemble it according to the computability.

$$\mathbf{f}^e = \int_{V^e} \mathbf{N}^T \mathbf{b} dV + \int_{S_i^e} \mathbf{N}^T \bar{\mathbf{T}} dS \quad , \quad \mathbf{f} = \sum_e \mathbf{f}^e$$

7. Apply the displacement boundary conditions and solve the stiffness equation.
8. Calculate strain, stress and reaction force.

### 5.3. Finite Element Programming (Linear static case)

- **Program Structure**

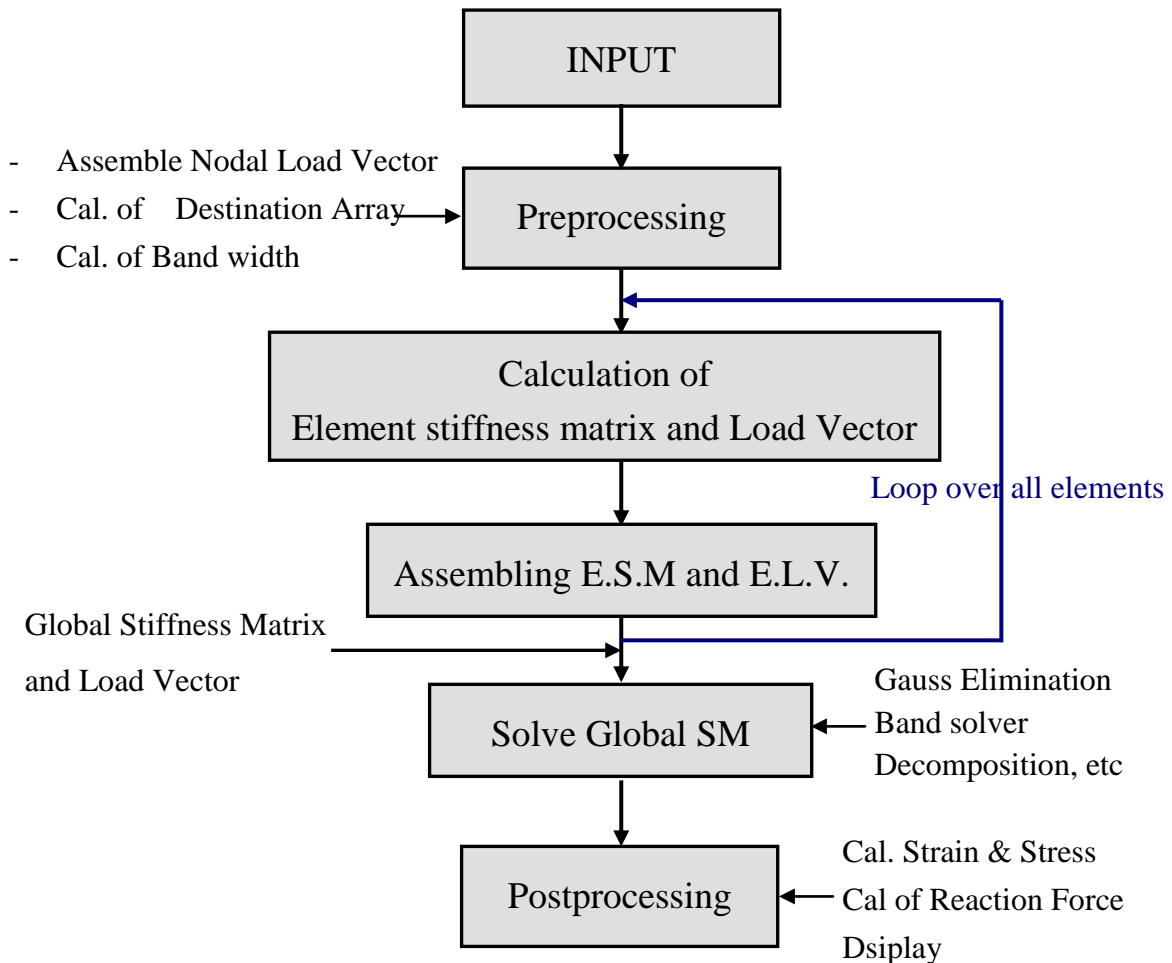

- **Data Structure**

- **Control Data :**
  - # of nodes, # of elements, # of support, # of forces applied at nodes...
- **Geometry Data :**
  - Nodal Coordinates
  - Element information (Type, Material Properties, Incidencies)
- **Material Properties**
- **Boundary Condition**
  - Traction boundary condition including forces applied at nodes
  - Displacement boundary condition
- Miscellaneous options

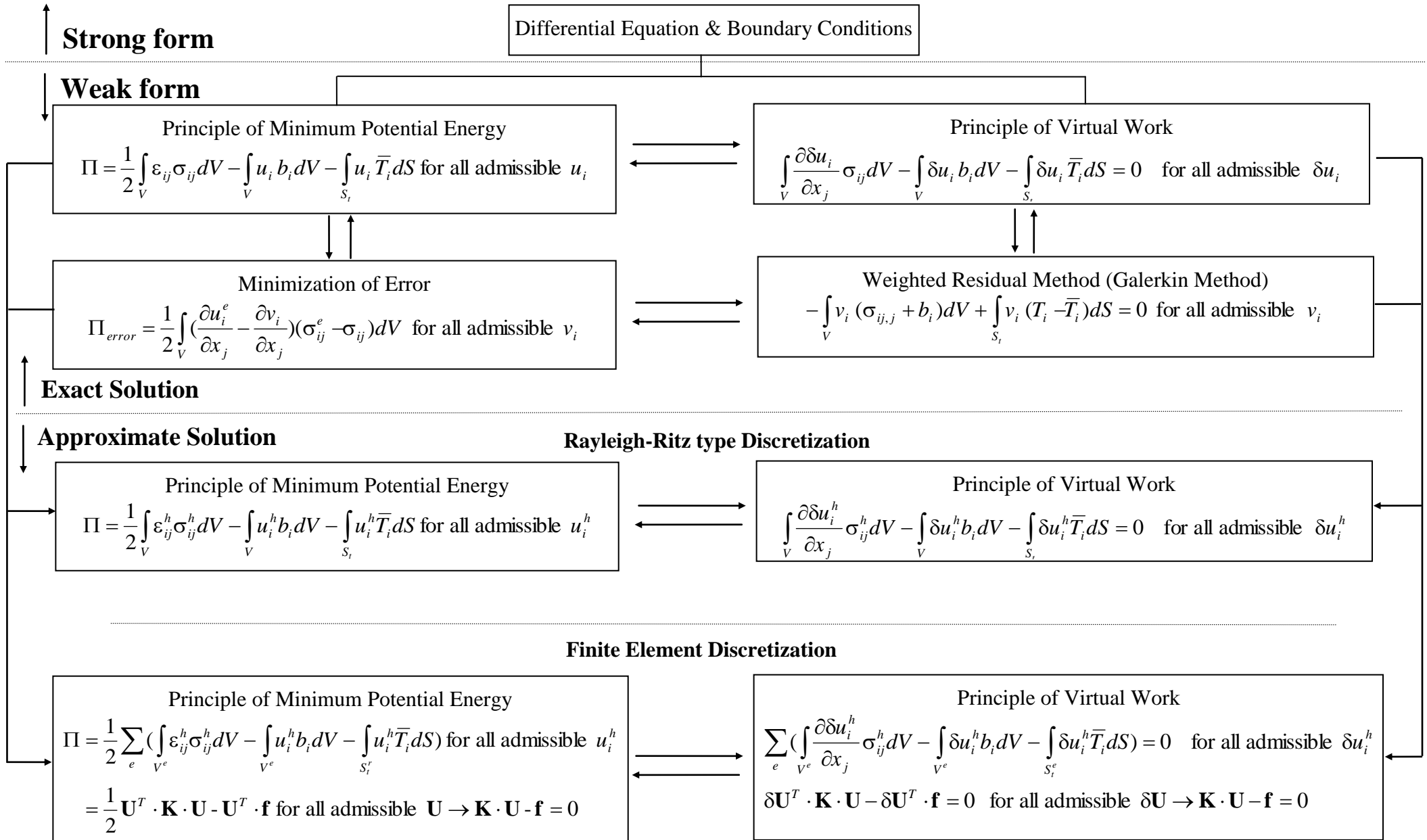

# Chapter 6

## Two-Dimensional Elasticity Problems

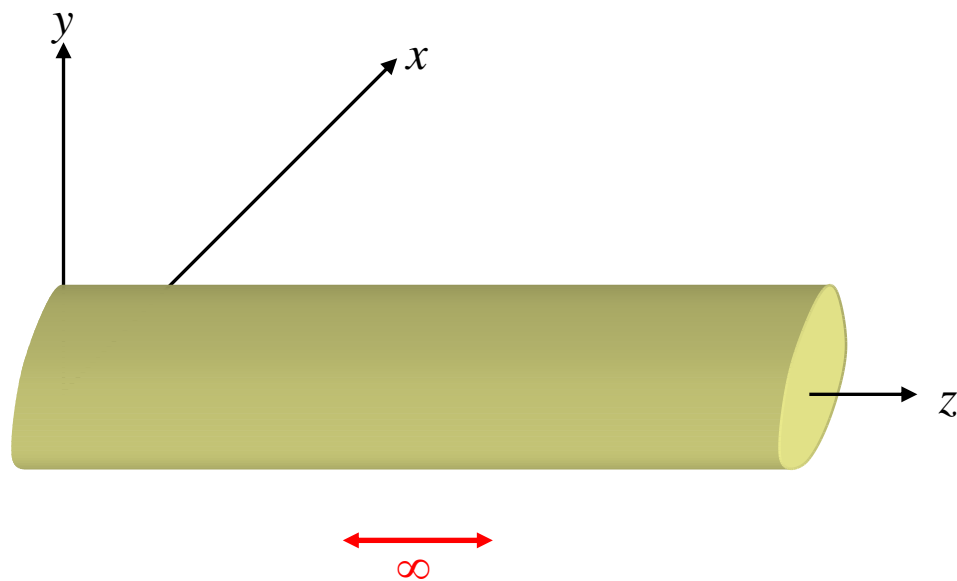

6.1. Plane Stress

6.2. Plane Strain

6.3. Axisymmetry

## 6.1. Plane Stress

- **Stress** :  $\sigma_{33} = \sigma_{13} = \sigma_{23} = 0$
- **Strain** :  $\varepsilon_{33} = -\frac{\nu}{1-\nu}(\varepsilon_{11} + \varepsilon_{22})$ ,  $\gamma_{13} = 0$ ,  $\gamma_{23} = 0$

- **Modified Stress-strain Relation**

$$\sigma_{11} = \frac{E(1-\nu)}{(1+\nu)(1-2\nu)}(\varepsilon_{11} + \frac{\nu}{1-\nu}(\varepsilon_{22} + \varepsilon_{33})) = \frac{E}{1-\nu^2}(\varepsilon_{11} + \nu\varepsilon_{22})$$

$$\sigma_{22} = \frac{E}{1-\nu^2}(\nu\varepsilon_{11} + \varepsilon_{22})$$

$$\sigma_{12} = \frac{E}{2(1+\nu)}\gamma_{12}$$

$$\boldsymbol{\sigma}^e = \begin{pmatrix} \sigma_{11}^e \\ \sigma_{22}^e \\ \sigma_{12}^e \end{pmatrix} = \frac{E}{1-\nu^2} \begin{bmatrix} 1 & \nu & 0 \\ \nu & 1 & 0 \\ 0 & 0 & \frac{1-\nu}{2} \end{bmatrix} \begin{pmatrix} \varepsilon_{11}^e \\ \varepsilon_{22}^e \\ \gamma_{12}^e \end{pmatrix} = \mathbf{D}\boldsymbol{\varepsilon}^e$$

- **Interpolation of Displacement**

$$\mathbf{u}^e = \begin{pmatrix} u^e \\ v^e \end{pmatrix} = \begin{bmatrix} N_1 & 0 & N_2 & 0 & \dots & N_n & 0 \\ 0 & N_1 & 0 & N_2 & \dots & 0 & N_n \end{bmatrix} \begin{pmatrix} u_1 \\ v_1 \\ u_2 \\ v_2 \\ \vdots \\ u_n \\ v_n \end{pmatrix} = \mathbf{N}^e \mathbf{U}^e$$

- **Strain-Displacement Relation**

$$\boldsymbol{\varepsilon}^e = \begin{pmatrix} \varepsilon_{11}^e \\ \varepsilon_{22}^e \\ \gamma_{12}^e \end{pmatrix} = \begin{pmatrix} \frac{\partial u^e}{\partial x} \\ \frac{\partial v^e}{\partial y} \\ \frac{\partial u^e}{\partial y} + \frac{\partial v^e}{\partial x} \end{pmatrix} = \begin{bmatrix} \frac{\partial N_1}{\partial x} & 0 & \frac{\partial N_2}{\partial x} & 0 & \dots & \frac{\partial N_n}{\partial x} & 0 \\ 0 & \frac{\partial N_1}{\partial y} & 0 & \frac{\partial N_2}{\partial y} & \dots & 0 & \frac{\partial N_n}{\partial y} \\ \frac{\partial N_1}{\partial y} & \frac{\partial N_1}{\partial x} & \frac{\partial N_2}{\partial y} & \frac{\partial N_2}{\partial x} & \dots & \frac{\partial N_n}{\partial y} & \frac{\partial N_n}{\partial x} \end{bmatrix} \begin{pmatrix} u_1 \\ v_1 \\ u_2 \\ v_2 \\ \vdots \\ u_n \\ v_n \end{pmatrix} = \mathbf{B}\mathbf{U}^e$$

- **Principle of Virtual work**

$$\int_A (\delta\varepsilon_{11}^h \sigma_{11}^h + \delta\varepsilon_{22}^h \sigma_{22}^h + \delta\gamma_{12}^h \sigma_{12}^h) t dA = \int_A (\delta u^h b_x + \delta v^h b_y) t dA + \int_{S_i} (\delta u^h T_x + \delta v^h T_y) t dS$$

$$\sum_e \int_{A^e} \mathbf{B}^T \cdot \mathbf{D} \cdot \mathbf{B} t dA \mathbf{U} = \sum_e \int_{A^e} \mathbf{N}^T \cdot \mathbf{b} t dA + \sum_e \int_{S^e} \mathbf{N}^T \cdot \mathbf{T} t dS$$



## 6.2. Plane Strain

- **Strain** :  $\varepsilon_{33} = 0, \gamma_{13} = 0, \gamma_{23} = 0$
- **Stress** :  $\sigma_{13} = \sigma_{23} = 0, \sigma_{33} = -\nu(\sigma_{11} + \sigma_{22})$
- **Stress-strain Relation**

$$\boldsymbol{\sigma}^e = \begin{pmatrix} \sigma_{11}^e \\ \sigma_{22}^e \\ \sigma_{12}^e \end{pmatrix} = \frac{E(1-\nu)}{(1+\nu)(1-2\nu)} \begin{bmatrix} 1 & \frac{\nu}{1-\nu} & 0 \\ \frac{\nu}{1-\nu} & 1 & 0 \\ 0 & 0 & \frac{1-2\nu}{2(1-\nu)} \end{bmatrix} \begin{pmatrix} \varepsilon_{11}^e \\ \varepsilon_{22}^e \\ \gamma_{12}^e \end{pmatrix} = \mathbf{D}\boldsymbol{\varepsilon}^e$$

- **Interpolation of Displacement**

$$\mathbf{u}^e = \begin{pmatrix} u^e \\ v^e \end{pmatrix} = \begin{bmatrix} N_1 & 0 & N_2 & 0 & \dots & N_n & 0 \\ 0 & N_1 & 0 & N_2 & \dots & 0 & N_n \end{bmatrix} \begin{pmatrix} u_1 \\ v_1 \\ u_2 \\ v_2 \\ \vdots \\ u_n \\ v_n \end{pmatrix} = \mathbf{N}^e \mathbf{U}^e$$

- **Strain-Displacement Relation**

$$\boldsymbol{\varepsilon}^e = \begin{pmatrix} \varepsilon_{11}^e \\ \varepsilon_{22}^e \\ \gamma_{12}^e \end{pmatrix} = \begin{pmatrix} \frac{\partial u^e}{\partial x} \\ \frac{\partial v^e}{\partial y} \\ \frac{\partial u^e}{\partial y} + \frac{\partial v^e}{\partial x} \end{pmatrix} = \begin{bmatrix} \frac{\partial N_1}{\partial x} & 0 & \frac{\partial N_2}{\partial x} & 0 & \dots & \frac{\partial N_n}{\partial x} & 0 \\ 0 & \frac{\partial N_1}{\partial y} & 0 & \frac{\partial N_2}{\partial y} & \dots & 0 & \frac{\partial N_n}{\partial y} \\ \frac{\partial N_1}{\partial y} & \frac{\partial N_1}{\partial x} & \frac{\partial N_2}{\partial y} & \frac{\partial N_2}{\partial x} & \dots & \frac{\partial N_n}{\partial y} & \frac{\partial N_n}{\partial x} \end{bmatrix} \begin{pmatrix} u_1 \\ v_1 \\ u_2 \\ v_2 \\ \vdots \\ u_n \\ v_n \end{pmatrix} = \mathbf{B}\mathbf{U}^e$$

- **Principle of Virtual work**

$$\int_A (\delta \varepsilon_{11}^h \sigma_{11}^h + \delta \varepsilon_{22}^h \sigma_{22}^h + \delta \gamma_{12}^h \sigma_{12}^h) t dA = \int_A (\delta u^h b_x + \delta v^h b_y) t dA + \int_{S_i} (\delta u^h T_x + \delta v^h T_y) t dS$$

$$\sum_e \int_{A^e} \mathbf{B}^T \cdot \mathbf{D} \cdot \mathbf{B} t dA U = \sum_e \int_{A^e} \mathbf{N}^T \cdot \mathbf{b} t dA + \sum_e \int_{S^e} \mathbf{N}^T \cdot \mathbf{T} t dS$$

### 6.3. Axisymmetry

- **Strain** :  $\varepsilon_{rr} = \frac{\partial u}{\partial r}$ ,  $\varepsilon_{zz} = \frac{\partial v}{\partial z}$ ,  $\varepsilon_{\theta\theta} = \frac{u}{r}$ ,  $\gamma_{rz} = \frac{\partial u}{\partial z} + \frac{\partial v}{\partial r}$ ,  $\gamma_{r\theta} = 0$ ,  $\gamma_{z\theta} = 0$

- **Stress** :  $\sigma_{r\theta} = \sigma_{z\theta} = 0$

- **Stress-strain Relation**

$$\boldsymbol{\sigma}^e = \begin{pmatrix} \sigma_{rr}^e \\ \sigma_{zz}^e \\ \sigma_{\theta\theta}^e \\ \sigma_{rz}^e \end{pmatrix} = \frac{E(1-\nu)}{(1+\nu)(1-2\nu)} \begin{bmatrix} 1 & \frac{\nu}{1-\nu} & \frac{\nu}{1-\nu} & 0 \\ \frac{\nu}{1-\nu} & 1 & \frac{\nu}{1-\nu} & 0 \\ \frac{\nu}{1-\nu} & \frac{\nu}{1-\nu} & 1 & 0 \\ 0 & 0 & 0 & \frac{1-2\nu}{2(1-\nu)} \end{bmatrix} \begin{pmatrix} \varepsilon_{rr}^e \\ \varepsilon_{zz}^e \\ \varepsilon_{\theta\theta}^e \\ \gamma_{rz}^e \end{pmatrix} = \mathbf{D}\boldsymbol{\varepsilon}^e$$

- **Interpolation of Displacement**

$$\mathbf{u}^e = \begin{pmatrix} u^e \\ v^e \end{pmatrix} = \begin{bmatrix} N_1 & 0 & N_2 & 0 & \dots & N_n & 0 \\ 0 & N_1 & 0 & N_2 & \dots & 0 & N_n \end{bmatrix} \begin{pmatrix} u_1 \\ v_1 \\ u_2 \\ v_2 \\ \vdots \\ u_n \\ v_n \end{pmatrix} = \mathbf{N}^e \mathbf{U}^e$$

- **Strain-Displacement Relation**

$$\boldsymbol{\varepsilon}^e = \begin{pmatrix} \varepsilon_{rr}^e \\ \varepsilon_{zz}^e \\ \varepsilon_{\theta\theta}^e \\ \gamma_{rz}^e \end{pmatrix} = \begin{pmatrix} \frac{\partial u^e}{\partial r} \\ \frac{\partial v^e}{\partial z} \\ \frac{u^e}{r} \\ \frac{\partial u^e}{\partial z} + \frac{\partial v^e}{\partial r} \end{pmatrix} = \begin{bmatrix} \frac{\partial N_1}{\partial r} & 0 & \frac{\partial N_2}{\partial r} & 0 & \dots & \frac{\partial N_n}{\partial r} & 0 \\ 0 & \frac{\partial N_1}{\partial z} & 0 & \frac{\partial N_2}{\partial z} & \dots & 0 & \frac{\partial N_n}{\partial z} \\ \frac{N_1}{r} & 0 & \frac{N_2}{r} & 0 & \dots & \frac{N_n}{r} & 0 \\ \frac{\partial N_1}{\partial z} & \frac{\partial N_1}{\partial r} & \frac{\partial N_2}{\partial z} & \frac{\partial N_2}{\partial r} & \dots & \frac{\partial N_n}{\partial z} & \frac{\partial N_n}{\partial r} \end{bmatrix} \begin{pmatrix} u_1 \\ v_1 \\ u_2 \\ v_2 \\ \vdots \\ u_n \\ v_n \end{pmatrix} = \mathbf{B}\mathbf{U}^e$$

- **Principle of Virtual work**

$$\int_A (\delta\varepsilon_{rr}^h \sigma_{rr}^h + \delta\varepsilon_{zz}^h \sigma_{zz}^h + \delta\varepsilon_{\theta\theta}^h \sigma_{\theta\theta}^h + \delta\gamma_{r\theta}^h \sigma_{r\theta}^h) 2\pi r dr dA = \int_A (\delta u^h b_r + \delta v^h b_z) 2\pi r dr dA + \int_{S_i} (\delta u^h T_r + \delta v^h T_z) 2\pi r ds$$

$$\sum_e \int_{A^e} \mathbf{B}^T \cdot \mathbf{D} \cdot \mathbf{B} 2\pi r dr dA \mathbf{U} = \sum_e \int_{A^e} \mathbf{N}^T \cdot \mathbf{b} 2\pi r dr dA + \sum_e \int_{S^e} \mathbf{N}^T \cdot \mathbf{T} 2\pi r ds$$

# Chapter 7

## Various Types of Elements

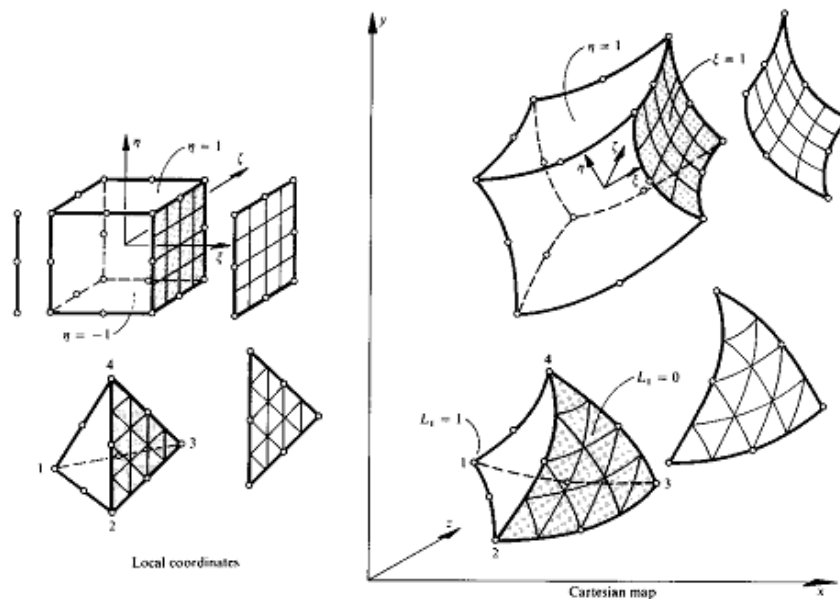

7.1. Constant Strain Triangle (CST) Element

7.2. Isoparametric Formulation

7.3. Bilinear Isoparametric Element

7.4. Higher Order Rectangular Element - Lagrange Family

7.5. Higher Order Rectangular Element - Serendipity Family

7.6. Triangular Isoparametric Element

## 7.1. Constant Strain Triangle (CST) Element

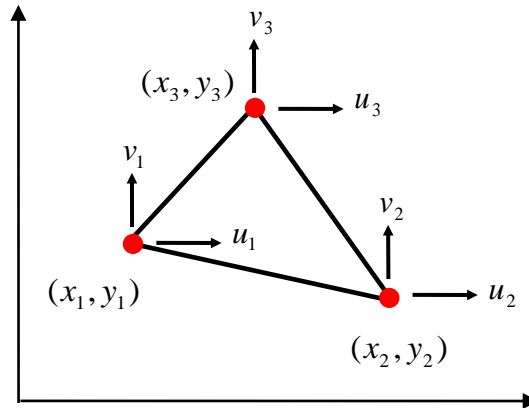

- Displacement Interpolation**

$$u^e(x, y) = \alpha_1 + \alpha_2 x + \alpha_3 y, \quad v^e(x, y) = \alpha_4 + \alpha_5 x + \alpha_6 y$$

$$\begin{aligned} u^e(x_1, y_1) = u_1 &= \alpha_1 + \alpha_2 x_1 + \alpha_3 y_1 \\ u^e(x_2, y_2) = u_2 &= \alpha_1 + \alpha_2 x_2 + \alpha_3 y_2 \\ u^e(x_3, y_3) = u_3 &= \alpha_1 + \alpha_2 x_3 + \alpha_3 y_3 \end{aligned} \rightarrow \begin{pmatrix} u_1 \\ u_2 \\ u_3 \end{pmatrix} = \begin{bmatrix} 1 & x_1 & y_1 \\ 1 & x_2 & y_2 \\ 1 & x_3 & y_3 \end{bmatrix} \begin{pmatrix} \alpha_1 \\ \alpha_2 \\ \alpha_3 \end{pmatrix}$$

$$\begin{pmatrix} \alpha_1 \\ \alpha_2 \\ \alpha_3 \end{pmatrix} = \begin{bmatrix} 1 & x_1 & y_1 \\ 1 & x_2 & y_2 \\ 1 & x_3 & y_3 \end{bmatrix}^{-1} \begin{pmatrix} u_1 \\ u_2 \\ u_3 \end{pmatrix} = \frac{1}{2\Delta} \begin{bmatrix} a_1 & a_2 & a_3 \\ b_1 & b_2 & b_3 \\ c_1 & c_2 & c_3 \end{bmatrix} \begin{pmatrix} u_1 \\ u_2 \\ u_3 \end{pmatrix}$$

$$\text{where } a_i = x_j y_m - x_m y_j, \quad b_i = y_j - y_m, \quad c_i = x_m - x_j$$

$$\begin{aligned} u^e(x, y) &= \frac{1}{2\Delta} (a_1 + b_1 x + c_1 y) u_1 + \frac{1}{2\Delta} (a_2 + b_2 x + c_2 y) u_2 + \frac{1}{2\Delta} (a_3 + b_3 x + c_3 y) u_3 \\ v^e(x, y) &= \frac{1}{2\Delta} (a_1 + b_1 x + c_1 y) v_1 + \frac{1}{2\Delta} (a_2 + b_2 x + c_2 y) v_2 + \frac{1}{2\Delta} (a_3 + b_3 x + c_3 y) v_3 \end{aligned}$$

- Strain Components**

$$\boldsymbol{\varepsilon}^e = \begin{pmatrix} \varepsilon_{11}^e \\ \varepsilon_{22}^e \\ \gamma_{12}^e \end{pmatrix} = \begin{pmatrix} \frac{\partial u^e}{\partial x} \\ \frac{\partial v^e}{\partial y} \\ \frac{\partial u^e}{\partial y} + \frac{\partial v^e}{\partial x} \end{pmatrix} = \frac{1}{2\Delta} \begin{bmatrix} b_1 & 0 & b_2 & 0 & b_3 & 0 \\ 0 & c_1 & 0 & c_2 & 0 & c_3 \\ c_1 & b_1 & c_2 & b_2 & c_3 & b_3 \end{bmatrix} \begin{pmatrix} u_1 \\ v_1 \\ u_2 \\ v_2 \\ u_3 \\ v_3 \end{pmatrix} = \mathbf{B} \mathbf{U}^e$$

- Stiffness Matrix**

$$\mathbf{K}^e = \int_{A^e} \mathbf{B}^T \cdot \mathbf{D} \cdot \mathbf{B} t dA = \mathbf{B}^T \cdot \mathbf{D} \cdot \mathbf{B} t \Delta^e$$

**Homework 6****- Cantilever Beam with three load cases -**

Implement your own finite element program for 2-D elasticity problems using CST element. When you build your program, consider expandability so that you can easily add other types of elements to your program for next homeworks.

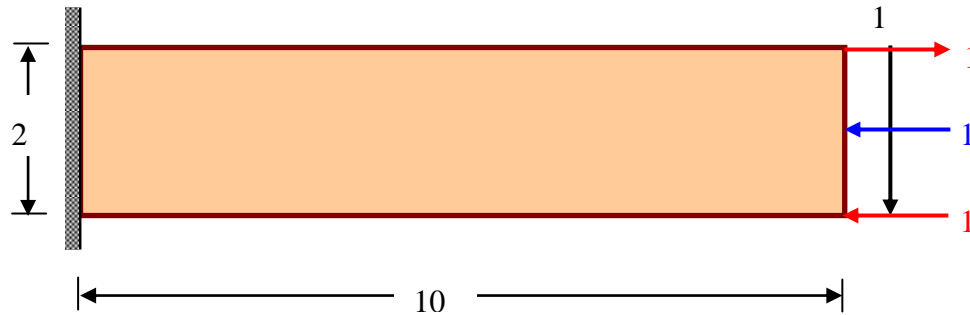

- Discuss how to simulate two boundary conditions given in the Timoshenko's book (equation (k) and (l) in page 44)
- For end shear load case, solve the problem for both boundary conditions with 40 CST elements.
- For other load cases, use one boundary condition of your choice with 40 CST elements
- Perform the convergence test with at least 5 different mesh layouts for the end shear load case. Use the boundary condition of your choice.
- Discuss local effects, St-Venant effect, Poisson effect stress concentration, etc. Present suitable plots and tables of displacement and stress to justify or clarify your discussions.
- Comparison of your results with other solutions such as analytic solutions, one-dimensional solutions is strongly recommended for your discussion. Assume  $E = 1.0$ ,  $\nu = 0.3$ .

## 7.2. Isoparametric Formulation

- Interpolation of Geometry

$$x = \bar{N}_1(\xi, \eta)x_1 + \bar{N}_2(\xi, \eta)x_2 + \dots + \bar{N}_m(\xi, \eta)x_m = \sum_{i=1}^m \bar{N}_i(\xi, \eta)x_i$$

$$y = \bar{N}_1(\xi, \eta)y_1 + \bar{N}_2(\xi, \eta)y_2 + \dots + \bar{N}_m(\xi, \eta)y_m = \sum_{i=1}^m \bar{N}_i(\xi, \eta)y_i$$

$$\mathbf{x}^e = \begin{pmatrix} x^e \\ y^e \end{pmatrix} = \begin{bmatrix} \bar{N}_1 & 0 & \bar{N}_2 & 0 & \dots & \bar{N}_m & 0 \\ 0 & \bar{N}_1 & 0 & \bar{N}_2 & \dots & 0 & \bar{N}_m \end{bmatrix} \begin{pmatrix} x_1 \\ y_1 \\ x_2 \\ y_2 \\ \vdots \\ x_m \\ y_m \end{pmatrix} = \bar{\mathbf{N}}^e \mathbf{X}^e$$

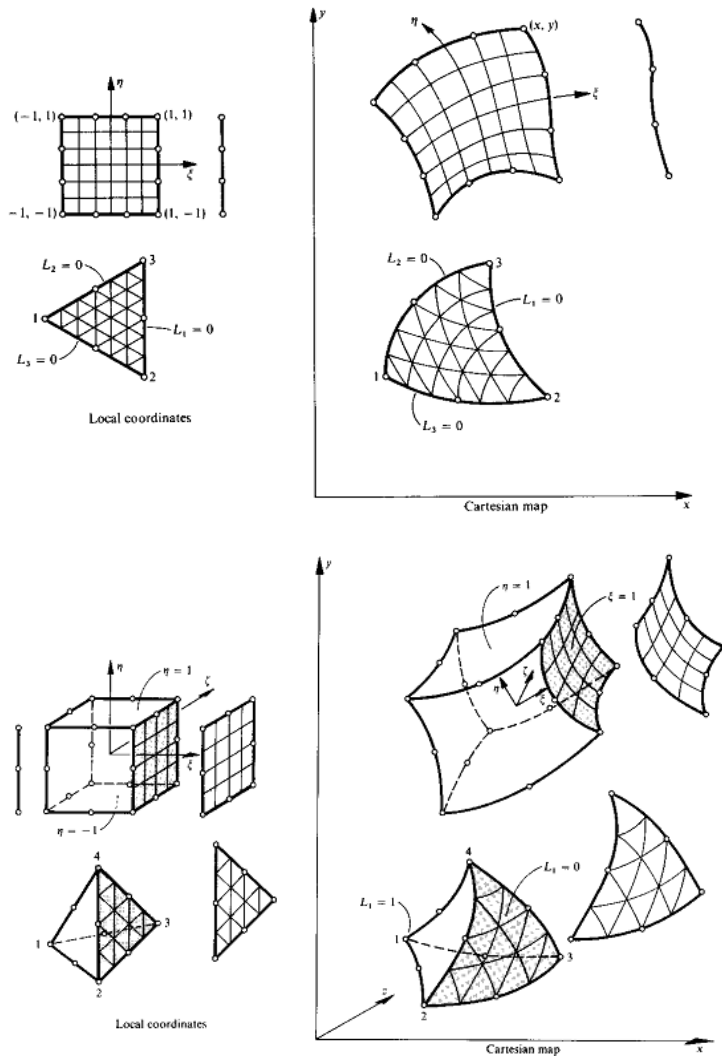

- **Interpolation of Displacement in a Parent Element**

$$\mathbf{u}^e = \begin{pmatrix} u^e \\ v^e \end{pmatrix} = \mathbf{N}^e(\xi, \eta) \mathbf{U}^e$$

- **Derivatives of the Displacement Shape Functions**

$$\left. \begin{aligned} \frac{\partial N_i}{\partial \xi} &= \frac{\partial N_i}{\partial x} \frac{\partial x}{\partial \xi} + \frac{\partial N_i}{\partial y} \frac{\partial y}{\partial \xi} \\ \frac{\partial N_i}{\partial \eta} &= \frac{\partial N_i}{\partial x} \frac{\partial x}{\partial \eta} + \frac{\partial N_i}{\partial y} \frac{\partial y}{\partial \eta} \end{aligned} \right\} \rightarrow \begin{pmatrix} \frac{\partial N_i}{\partial \xi} \\ \frac{\partial N_i}{\partial \eta} \end{pmatrix} = \begin{bmatrix} \frac{\partial x}{\partial \xi} & \frac{\partial y}{\partial \xi} \\ \frac{\partial x}{\partial \eta} & \frac{\partial y}{\partial \eta} \end{bmatrix} \begin{pmatrix} \frac{\partial N_i}{\partial x} \\ \frac{\partial N_i}{\partial y} \end{pmatrix} \rightarrow$$

$$\begin{pmatrix} \frac{\partial N_i}{\partial x} \\ \frac{\partial N_i}{\partial y} \end{pmatrix} = \begin{bmatrix} \frac{\partial x}{\partial \xi} & \frac{\partial y}{\partial \xi} \\ \frac{\partial x}{\partial \eta} & \frac{\partial y}{\partial \eta} \end{bmatrix}^{-1} \begin{pmatrix} \frac{\partial N_i}{\partial \xi} \\ \frac{\partial N_i}{\partial \eta} \end{pmatrix} = \mathbf{J}^{-1} \begin{pmatrix} \frac{\partial N_i}{\partial \xi} \\ \frac{\partial N_i}{\partial \eta} \end{pmatrix} \quad \text{or} \quad \nabla_x N_i = \mathbf{J}^{-1} \nabla_\eta N$$

$$\mathbf{J} = \begin{bmatrix} \frac{\partial x}{\partial \xi} & \frac{\partial y}{\partial \xi} \\ \frac{\partial x}{\partial \eta} & \frac{\partial y}{\partial \eta} \end{bmatrix} = \begin{bmatrix} \sum_{i=1}^m \frac{\partial \bar{N}_i}{\partial \xi} x_i & \sum_{i=1}^m \frac{\partial \bar{N}_i}{\partial \xi} y_i \\ \sum_{i=1}^m \frac{\partial \bar{N}_i}{\partial \eta} x_i & \sum_{i=1}^m \frac{\partial \bar{N}_i}{\partial \eta} y_i \end{bmatrix} = \begin{bmatrix} \frac{\partial \bar{N}_1}{\partial \xi} & \frac{\partial \bar{N}_2}{\partial \xi} & \dots & \frac{\partial \bar{N}_m}{\partial \xi} \\ \frac{\partial \bar{N}_1}{\partial \eta} & \frac{\partial \bar{N}_2}{\partial \eta} & \dots & \frac{\partial \bar{N}_m}{\partial \eta} \end{bmatrix} \begin{bmatrix} x_1 & y_1 \\ x_2 & y_2 \\ \vdots & \vdots \\ x_m & y_m \end{bmatrix} = \nabla_\xi \bar{\mathbf{N}} \cdot \mathbf{X}$$

$m > n$   $N \neq \bar{N}$  : Superparametric element

$m = n$   $N = \bar{N}$  : **Isoparametric element**

$m < n$   $N \neq \bar{N}$  : Subparametric element

$$\int_{A^e} \mathbf{B}^T \cdot \mathbf{D} \cdot \mathbf{B} t dA = \int_{-1}^1 \int_{-1}^1 \mathbf{B}^T(\xi, \eta) \cdot \mathbf{D} \cdot \mathbf{B}(\xi, \eta) t |J| d\xi d\eta$$

### 7.3. Bilinear Isoparametric Element

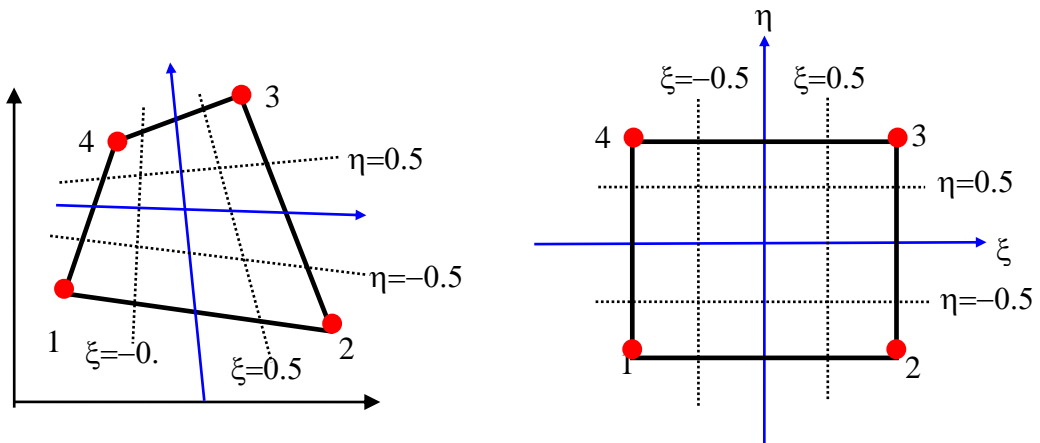

- Shape functions in the parent coordinate system.

$$u(x(\xi, \eta), y(\xi, \eta)) = \alpha_1 + \alpha_2\xi + \alpha_3\eta + \alpha_4\xi\eta$$

$$v(x(\xi, \eta), y(\xi, \eta)) = \alpha_5 + \alpha_6\xi + \alpha_7\eta + \alpha_8\xi\eta$$

$$u_1 = u(x_1, y_1) = u(x(\xi_1, \eta_1), y(\xi_1, \eta_1)) = \alpha_1 + \alpha_2\xi_1 + \alpha_3\eta_1 + \alpha_4\xi_1\eta_1 = \alpha_1 - \alpha_2 - \alpha_3 + \alpha_4$$

$$u_2 = u(x_2, y_2) = u(x(\xi_2, \eta_2), y(\xi_2, \eta_2)) = \alpha_1 + \alpha_2\xi_2 + \alpha_3\eta_2 + \alpha_4\xi_2\eta_2 = \alpha_1 + \alpha_2 - \alpha_3 - \alpha_4$$

$$u_3 = u(x_3, y_3) = u(x(\xi_3, \eta_3), y(\xi_3, \eta_3)) = \alpha_1 + \alpha_2\xi_3 + \alpha_3\eta_3 + \alpha_4\xi_3\eta_3 = \alpha_1 + \alpha_2 + \alpha_3 + \alpha_4$$

$$u_4 = u(x_4, y_4) = u(x(\xi_4, \eta_4), y(\xi_4, \eta_4)) = \alpha_1 + \alpha_2\xi_4 + \alpha_3\eta_4 + \alpha_4\xi_4\eta_4 = \alpha_1 - \alpha_2 + \alpha_3 - \alpha_4$$

$$\begin{pmatrix} u_1 \\ u_2 \\ u_3 \\ u_4 \end{pmatrix} = \begin{bmatrix} 1 & -1 & -1 & 1 \\ 1 & 1 & -1 & -1 \\ 1 & 1 & 1 & 1 \\ 1 & -1 & 1 & -1 \end{bmatrix} \begin{pmatrix} \alpha_1 \\ \alpha_2 \\ \alpha_3 \\ \alpha_4 \end{pmatrix}$$

$$u^e(x, y) = N_1u^1 + N_2u^2 + N_3u^3 + N_4u^4, \quad v^e(x, y) = N_1v^1 + N_2v^2 + N_3v^3 + N_4v^4$$

$$N_1 = \frac{1}{4}(1-\xi)(1-\eta), \quad N_2 = \frac{1}{4}(1+\xi)(1-\eta), \quad N_3 = \frac{1}{4}(1+\xi)(1+\eta), \quad N_4 = \frac{1}{4}(1-\xi)(1+\eta)$$

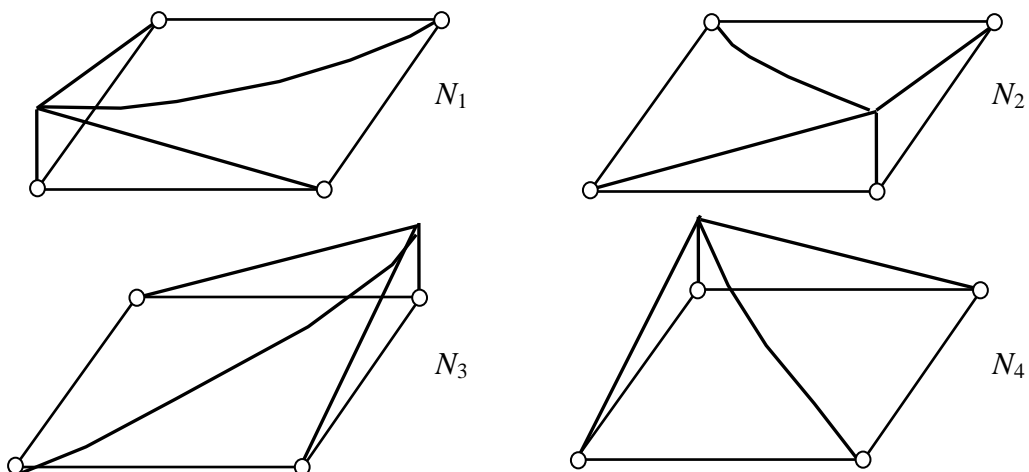



### 7.4. Higher Order Rectangular Element - *Lagrange Family*

- Shape Function of m-th Order for k-th Node in One Dimension

$$l_k^m(\xi) = \frac{(\xi - \xi_1)(\xi - \xi_2) \cdots (\xi - \xi_{k-1})(\xi - \xi_{k+1}) \cdots (\xi - \xi_{m+1})}{(\xi_k - \xi_1)(\xi_k - \xi_2) \cdots (\xi_k - \xi_{k-1})(\xi_k - \xi_{k+1}) \cdots (\xi_k - \xi_{m+1})}$$

$$l_k^m(\eta) = \frac{(\eta - \eta_1)(\eta - \eta_2) \cdots (\eta - \eta_{k-1})(\eta - \eta_{k+1}) \cdots (\eta - \eta_{m+1})}{(\eta_k - \eta_1)(\eta_k - \eta_2) \cdots (\eta_k - \eta_{k-1})(\eta_k - \eta_{k+1}) \cdots (\eta_k - \eta_{m+1})}$$

$$N_i = N_{IJ} = l_I^m(\xi) \times l_J^m(\eta)$$

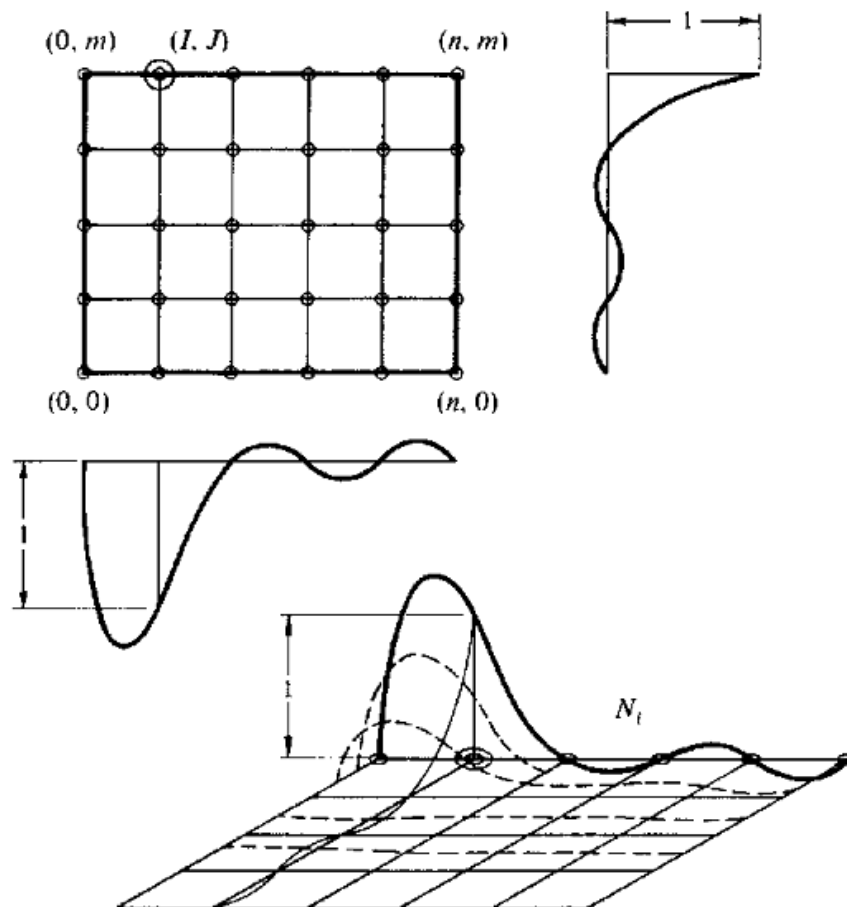

• Q9 Element

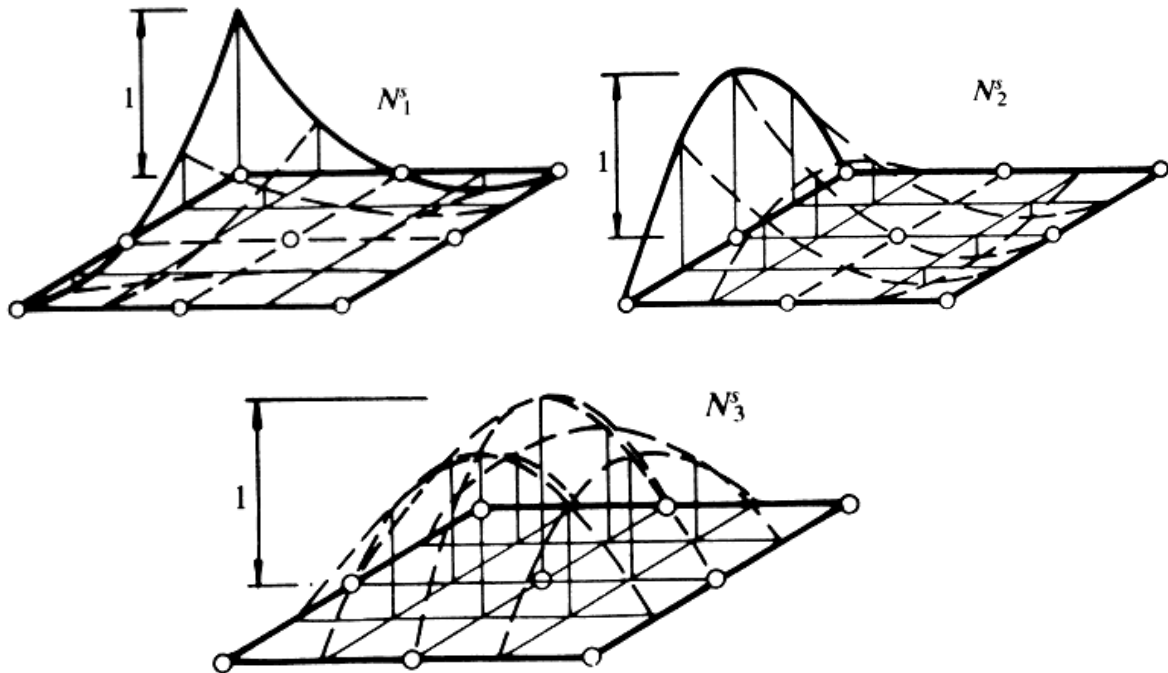

- Total number of nodes in an element :  $(m+1)(m+1)$
- Total number of terms in m-th order polynomials :  $\frac{(m+2)(m+1)}{2}$
- Total number of the parasitic terms :  $\frac{(m+1)m}{2}$
- The Pascal Polynomials

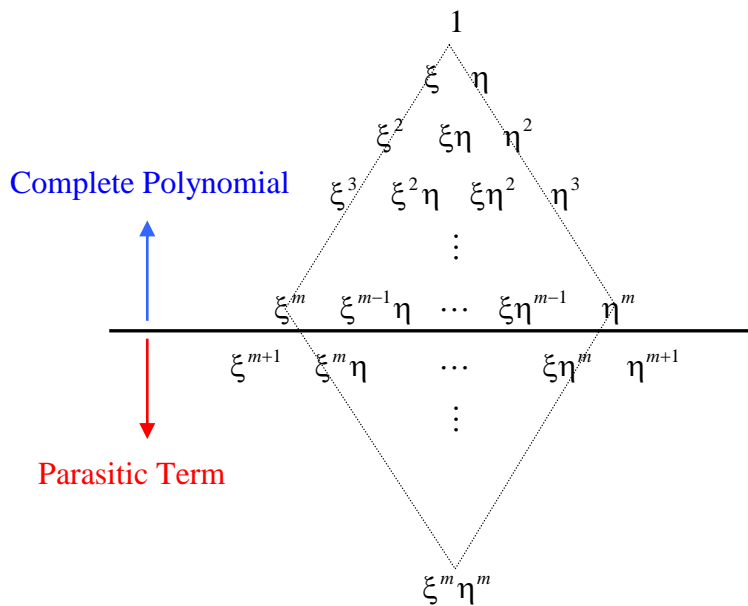

### 7.5. Higher Order Rectangular Element - Serendipity Family

- Q8 Element

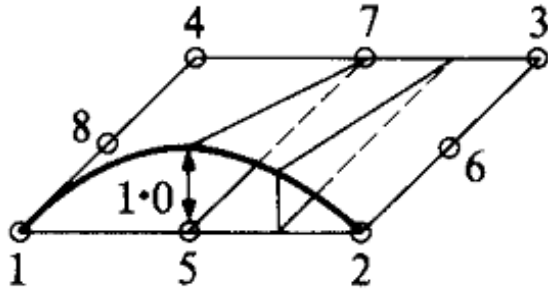

$$N_5 = \frac{1}{2}(1 - \xi^2)(1 - \eta)$$

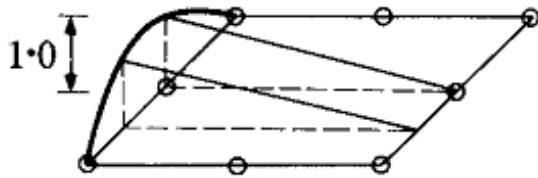

$$N_8 = \frac{1}{2}(1 - \xi)(1 - \eta^2)$$

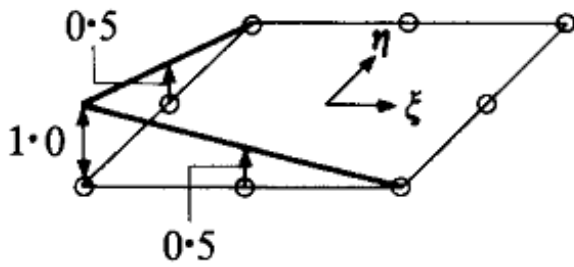

$$\hat{N}_1 = \frac{1}{4}(1 - \xi)(1 - \eta)$$

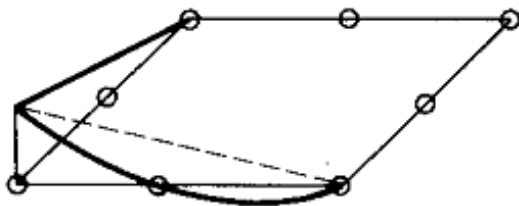

$$\hat{N}_1 = \frac{1}{2}N_5$$

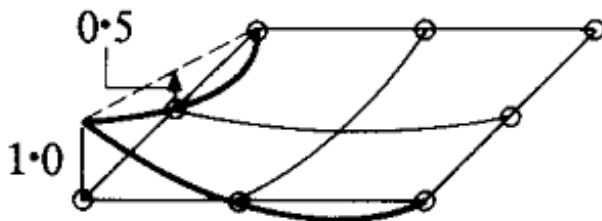

$$N_1 = \hat{N}_1 - \frac{1}{2}N_5 - \frac{1}{2}N_8$$

### 7.6. Triangular Isoparametric Element

- Total number of nodes on sides of a triangle element for m-th order S.F.:  $3m$
- Total number of terms in m-th order polynomials :  $\frac{(m+2)(m+1)}{2}$
- Total number of internal nodes :  $\frac{(m+2)(m+1)}{2} - 3m = \frac{(m-2)(m-1)}{2}$
- The Pascal Polynomials

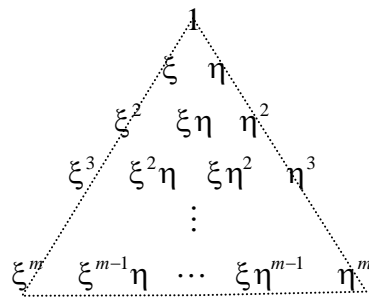

- Area Coordinate System

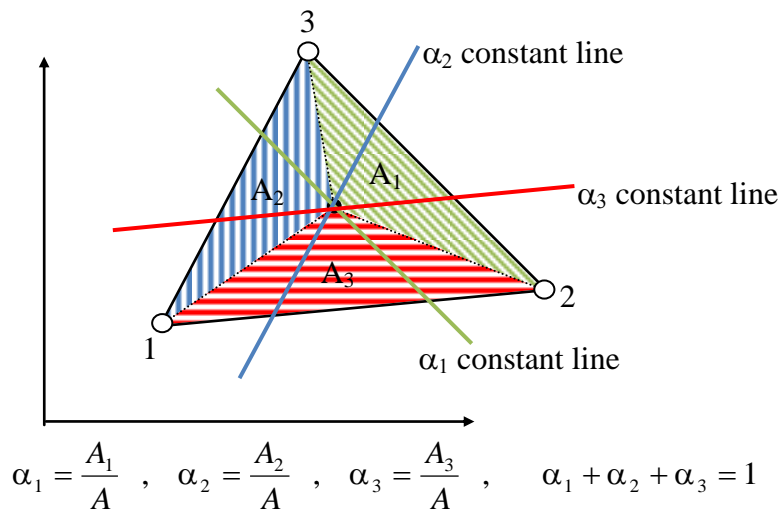

- Shape functions

- CST Element

$$N_1 = \alpha_1, \quad N_2 = \alpha_2, \quad N_3 = \alpha_3$$

- LST Element

$$\begin{aligned} N_1 &= \alpha_1(2\alpha_1 - 1) & N_2 &= \alpha_2(2\alpha_2 - 1) & N_3 &= \alpha_3(2\alpha_3 - 1) \\ N_4 &= 4\alpha_1\alpha_2 & N_5 &= 4\alpha_2\alpha_3 & N_6 &= 4\alpha_1\alpha_3 \end{aligned}$$

- **Interpolation of Geometry**

$$x = \sum_{i=1}^n N_i(\alpha_1, \alpha_2, \alpha_3) x_i = \sum_{i=1}^n \tilde{N}_i(\alpha_1, \alpha_2) x_i$$

$$y = \sum_{i=1}^n N_i(\alpha_1, \alpha_2, \alpha_3) y_i = \sum_{i=1}^n \tilde{N}_i(\alpha_1, \alpha_2) y_i$$

$$(\mathbf{X}^e) = \begin{pmatrix} x^e \\ y^e \end{pmatrix} = \begin{bmatrix} \tilde{N}_1 & 0 & \tilde{N}_2 & 0 & \dots & \tilde{N}_n & 0 \\ 0 & \tilde{N}_1 & 0 & \tilde{N}_2 & \dots & 0 & \tilde{N}_n \end{bmatrix} \begin{pmatrix} x_1 \\ y_1 \\ x_2 \\ y_2 \\ \vdots \\ x_m \\ y_m \end{pmatrix} = [\tilde{\mathbf{N}}]^e (\mathbf{X}^e)$$

- **Interpolation of Displacement in a Parent Element**

$$(u^e) = \begin{pmatrix} u^e \\ v^e \end{pmatrix} = [N(\alpha_1, \alpha_2, \alpha_3)]^e (U^e) = [\tilde{N}(\alpha_1, \alpha_2)]^e (U^e)$$

- **Derivatives of the Displacement Shape Functions**

$$\left. \begin{aligned} \frac{\partial \tilde{N}_i}{\partial \alpha_1} &= \frac{\partial \tilde{N}_i}{\partial x} \frac{\partial x}{\partial \alpha_1} + \frac{\partial \tilde{N}_i}{\partial y} \frac{\partial y}{\partial \alpha_1} \\ \frac{\partial \tilde{N}_i}{\partial \alpha_2} &= \frac{\partial \tilde{N}_i}{\partial x} \frac{\partial x}{\partial \alpha_2} + \frac{\partial \tilde{N}_i}{\partial y} \frac{\partial y}{\partial \alpha_2} \end{aligned} \right\} \rightarrow \begin{pmatrix} \frac{\partial \tilde{N}_i}{\partial \alpha_1} \\ \frac{\partial \tilde{N}_i}{\partial \alpha_2} \end{pmatrix} = \begin{bmatrix} \frac{\partial x}{\partial \alpha_1} & \frac{\partial y}{\partial \alpha_1} \\ \frac{\partial x}{\partial \alpha_2} & \frac{\partial y}{\partial \alpha_2} \end{bmatrix} \begin{pmatrix} \frac{\partial \tilde{N}_i}{\partial x} \\ \frac{\partial \tilde{N}_i}{\partial y} \end{pmatrix} \rightarrow$$

$$\begin{pmatrix} \frac{\partial \tilde{N}_i}{\partial x} \\ \frac{\partial \tilde{N}_i}{\partial y} \end{pmatrix} = \begin{bmatrix} \frac{\partial x}{\partial \alpha_1} & \frac{\partial y}{\partial \alpha_1} \\ \frac{\partial x}{\partial \alpha_2} & \frac{\partial y}{\partial \alpha_2} \end{bmatrix}^{-1} \begin{pmatrix} \frac{\partial \tilde{N}_i}{\partial \alpha_1} \\ \frac{\partial \tilde{N}_i}{\partial \alpha_2} \end{pmatrix} = \mathbf{J}^{-1} \begin{pmatrix} \frac{\partial \tilde{N}_i}{\partial \alpha_1} \\ \frac{\partial \tilde{N}_i}{\partial \alpha_2} \end{pmatrix}$$

or

$$\nabla_x \tilde{N}_i = \mathbf{J}^{-1} \nabla_\alpha \tilde{N}_i$$

$$\mathbf{J} = \begin{bmatrix} \frac{\partial x}{\partial \alpha_1} & \frac{\partial y}{\partial \alpha_1} \\ \frac{\partial x}{\partial \alpha_2} & \frac{\partial y}{\partial \alpha_2} \end{bmatrix} = \begin{bmatrix} \sum_{i=1}^m \frac{\partial \tilde{N}_i}{\partial \alpha_1} x_i & \sum_{i=1}^m \frac{\partial \tilde{N}_i}{\partial \alpha_1} y_i \\ \sum_{i=1}^m \frac{\partial \tilde{N}_i}{\partial \alpha_2} x_i & \sum_{i=1}^m \frac{\partial \tilde{N}_i}{\partial \alpha_2} y_i \end{bmatrix} = \begin{bmatrix} \frac{\partial \tilde{N}_1}{\partial \alpha_1} & \frac{\partial \tilde{N}_2}{\partial \alpha_1} & \dots & \frac{\partial \tilde{N}_n}{\partial \alpha_1} \\ \frac{\partial \tilde{N}_1}{\partial \alpha_2} & \frac{\partial \tilde{N}_2}{\partial \alpha_2} & \dots & \frac{\partial \tilde{N}_n}{\partial \alpha_2} \end{bmatrix} \begin{bmatrix} x_1 & y_1 \\ x_2 & y_2 \\ \vdots & \vdots \\ x_m & y_m \end{bmatrix} = \nabla_\alpha \tilde{\mathbf{N}} \cdot \mathbf{X}$$

- **Homework 7**

Derive shape functions cubic serendipity element and triangle element in the parent coordinate.

This page is intentionally left blank.

# Chapter 8

## Numerical Integration

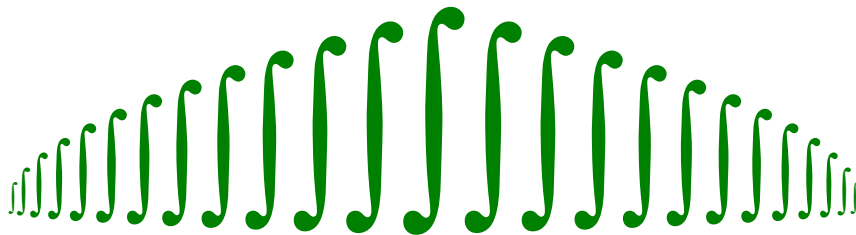

8.1 Gauss Quadrature Rule

8.2. Reduced Integration

8.3. Spurious Zero Energy mode

8.4. Selective Integration

## 8.1. Gauss Quadrature Rule

### • One Dimension

$$\int_{-1}^1 f(\xi) d\xi \approx \sum_{i=1}^n W_i f(\xi_i)$$

If the given function  $f(\xi)$  is a polynomial, it is possible to construct the quadrature rule that yields the exact integration.

-  $f(\xi)$  is constant:  $f(\xi) = a_0$

$$\int_{-1}^1 f(\xi) d\xi = 2a_0 = a_0 \sum_{i=1}^n W_i \rightarrow n=1 \quad W_1 = 2$$

-  $f(\xi)$  is first order:  $f(\xi) = a_0 + a_1\xi$  One point rule is good enough.

-  $f(\xi)$  is second order:  $f(\xi) = a_0 + a_1\xi + a_2\xi^2$

$$\int_{-1}^1 f(\xi) d\xi = \frac{2}{3}a_2 + 2a_0 = a_2 \sum_{i=1}^n W_i \xi_i^2 + a_1 \sum_{i=1}^n W_i \xi_i + a_0 \sum_{i=1}^n W_i \rightarrow$$

$$\sum_{i=1}^n W_i \xi_i^2 = \frac{2}{3}, \quad \sum_{i=1}^n W_i \xi_i = 0, \quad \sum_{i=1}^n W_i = 2 \rightarrow n = 2$$

$$\sum_{i=1}^n W_i \xi_i^1 = 0 \rightarrow W_1 = W_2, \quad \xi_1 = -\xi_2$$

$$\sum_{i=1}^2 W_i \xi_i^2 = W_1 \xi_1^2 + W_2 \xi_2^2 = 2W_2 \xi_2^2 = \frac{2}{3} \rightarrow W_2 \xi_2^2 = \frac{1}{3}$$

$$\sum_{i=1}^2 W_i = W_1 + W_2 = 2W_2 = 2 \rightarrow W_2 = 1 \rightarrow \xi_2 = \sqrt{1/3} = 0.57735 \ 02691 \ 89626$$

-  $f(\xi)$  is third order:  $f(\xi) = a_0 + a_1\xi + a_2\xi^2 + a_3\xi^3$  Two point rule is enough.

-  $f(\xi)$  is fourth order:  $f(\xi) = a_0 + a_1\xi + a_2\xi^2 + a_3\xi^3 + a_4\xi^4$

$$\int_{-1}^1 f(\xi) d\xi = \frac{2}{5}a_4 + \frac{2}{3}a_2 + 2a_0 =$$

$$a_4 \sum_{i=1}^n W_i \xi_i^4 + a_3 \sum_{i=1}^n W_i \xi_i^3 + a_2 \sum_{i=1}^n W_i \xi_i^2 + a_1 \sum_{i=1}^n W_i \xi_i + a_0 \sum_{i=1}^n W_i \rightarrow$$

$$\sum_{i=1}^n W_i \xi_i^4 = \frac{2}{5}, \quad \sum_{i=1}^n W_i \xi_i^3 = 0, \quad \sum_{i=1}^n W_i \xi_i^2 = \frac{2}{3}, \quad \sum_{i=1}^n W_i \xi_i = 0, \quad \sum_{i=1}^n W_i = 2 \rightarrow n = 3$$

$$\sum_{i=1}^n W_i \xi_i^3 = 0, \quad \sum_{i=1}^n W_i \xi_i = 0 \rightarrow W_1 = W_3, \quad \xi_1 = -\xi_3, \quad \xi_2 = 0$$

$$\sum_{i=1}^3 W_i \xi_i^4 = W_1 \xi_1^4 + W_3 \xi_3^4 = 2W_3 \xi_3^4 = \frac{2}{5} \rightarrow W_3 \xi_3^4 = \frac{1}{5}$$



$$\sum_{i=1}^2 W_i \xi_i^2 = W_1 \xi_1^2 + W_3 \xi_3^2 = 2W_3 \xi_3^2 = \frac{2}{3} \rightarrow W_3 \xi_3^2 = \frac{1}{3} \rightarrow \xi_3 = \sqrt{3/5}, W_3 = \frac{5}{9}$$

$$\xi_3 = 0.77459\ 66692\ 41483, W_3 = 0.55555\ 55555\ 55555$$

$$\sum_{i=1}^2 W_i = W_1 + W_2 + W_3 = 2W_3 + W_2 = 2 \rightarrow W_2 = \frac{8}{9} = 0.88888\ 88888\ 88888$$

- Because of the symmetry condition, we need to decide only  $n$  unknowns for  $n$ -points G.Q..
- We can integrate  $2n-1$ -th polynomials exactly with  $n$ -points G.Q. Since for  $2m$ -th order polynomials we have  $2m$  conditions for G.Q. -which means we can determine  $(m+1)$ -point G.Q..
- Stiffness Equation

$$\int_{V^e} \mathbf{B}^T \cdot \mathbf{D} \cdot \mathbf{B} dV = \int_{x^e} \mathbf{B}^T \cdot \mathbf{D} \cdot \mathbf{B} A dx = \int_{-1}^1 \mathbf{B}^T(\xi) \cdot \mathbf{D} \cdot \mathbf{B}(\xi) A |J| d\xi = \sum_{i=1}^n W_i \mathbf{B}^T(\xi_i) \cdot \mathbf{D}_i \cdot \mathbf{B}(\xi_i) A_i |J_i|$$

$$\int_{V^e} \mathbf{N}^T \cdot \mathbf{b} dV = \int_{x^e} \mathbf{N}^T \cdot \mathbf{b} A dx = \int_{-1}^1 \mathbf{N}^T(\xi) \cdot \mathbf{b}(\xi) A |J| d\xi = \sum_{i=1}^n W_i \mathbf{N}^T(\xi_i) \cdot \mathbf{b}(\xi_i) A_i |J_i|$$

### ● Two-dimensional Case – Rectangular Elements

- Quadrature rule

$$\int_{-1}^1 \int_{-1}^1 f(\xi, \eta) d\xi d\eta \approx \int_{-1}^1 \sum_{i=1}^n W_i f(\xi_i, \eta) d\eta = \sum_{j=1}^m W_j \sum_{i=1}^n W_i f(\xi_i, \eta_j) = \sum_{j=1}^m \sum_{i=1}^n W_i W_j f(\xi_i, \eta_j)$$

- Stiffness equation

$$\begin{aligned} \int_{A^e} \mathbf{B}^T \cdot \mathbf{D} \cdot \mathbf{B} t dA &= \int_{-1}^1 \int_{-1}^1 \mathbf{B}^T(\xi, \eta) \cdot \mathbf{D} \cdot \mathbf{B}(\xi, \eta) t |J| d\xi d\eta \\ &= \sum_{i=1}^n \sum_{j=1}^m W_i W_j \mathbf{B}^T(\xi_i, \eta_j) \cdot \mathbf{D}_{ij} \cdot \mathbf{B}(\xi_i, \eta_j) t_{ij} |J_{ij}| \end{aligned}$$

$$\int_{A^e} \mathbf{N}^T \cdot \mathbf{b} t dA = \int_{-1}^1 \int_{-1}^1 \mathbf{N}^T(\xi, \eta) \cdot \mathbf{b} t |J| d\xi d\eta = \sum_{i=1}^n \sum_{j=1}^m W_i W_j \mathbf{N}^T(\xi_i, \eta_j) \cdot \mathbf{b}_{ij} t_{ij} |J_{ij}|$$

$$\int_{S^e} \mathbf{N}^T \cdot \mathbf{T} t dS = \int_{-1}^1 \mathbf{N}^T(\xi, \eta_p) \cdot \mathbf{T} t |K| d\xi = \sum_{i=1}^n W_i \mathbf{N}^T(\xi_i, \eta_p) \cdot \mathbf{T}_{ij} t_{ij} |K_{ij}|$$

### ● Two-dimensional Case – Triangular Elements

$$\begin{aligned} \int_{A^e} \mathbf{B}^T \cdot \mathbf{D} \cdot \mathbf{B} t dA &= \int_0^{1-\alpha_1} \int_0^{\alpha_1} \mathbf{B}^T(\alpha_1, \alpha_2) \cdot \mathbf{D} \cdot \mathbf{B}(\alpha_1, \alpha_2) t |J| d\alpha_2 d\alpha_1 \\ &= \frac{1}{2} \sum_{i=1}^n W_i \mathbf{B}^T(\alpha_1^i, \alpha_2^i) \cdot \mathbf{D}_{ij} \cdot \mathbf{B}(\alpha_1^i, \alpha_2^i) t_i |J_i| \end{aligned}$$

## 8.2. Reduced Integration

- **Q8 element**

$$u = a_0 + a_1\xi + a_2\eta + a_3\xi^2 + a_4\xi\eta + a_5\eta^2 + a_6\xi^2\eta + a_7\xi\eta^2$$

$$v = b_0 + b_1\xi + b_2\eta + b_3\xi^2 + b_4\xi\eta + b_5\eta^2 + b_6\xi^2\eta + b_7\xi\eta^2$$

$$\frac{\partial u}{\partial \xi} = a_1 + 2a_3\xi + a_4\eta + 2a_6\xi\eta + a_7\eta^2, \quad \frac{\partial v}{\partial \xi} = b_1 + 2b_3\xi + b_4\eta + 2b_6\xi\eta + b_7\eta^2$$

$$\frac{\partial u}{\partial \eta} = a_2 + a_4\xi + 2a_5\eta + a_6\xi^2 + 2a_7\xi\eta, \quad \frac{\partial v}{\partial \eta} = b_2 + b_4\xi + 2b_5\eta + b_6\xi^2 + 2b_7\xi\eta$$

- **Terms in stiffness matrix**

- From complete polynomials:  $1, \xi, \eta, \xi^2, \xi\eta, \eta^2$

- From parasitic terms:  $\xi^2\eta, \xi\eta^2, \eta^3, \xi^3, \xi^2\eta^2, \xi^3\eta, \xi\eta^3, \eta^4, \xi^4$

- **Reduced Integration**

*Reduce the integration order by one to eliminate the effect of parasitic terms in the stiffness matrix*

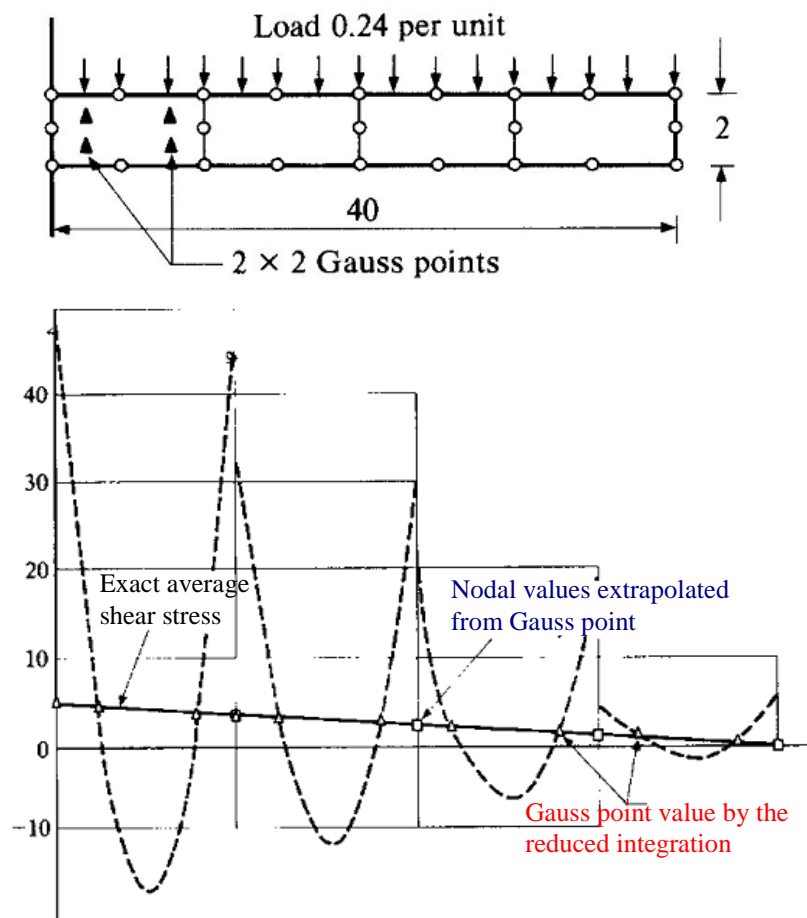

### 8.3. Spurious Zero Energy mode

- Independent Displacement Modes of a Bilinear Element

Rigid Body motion – zero energy mode

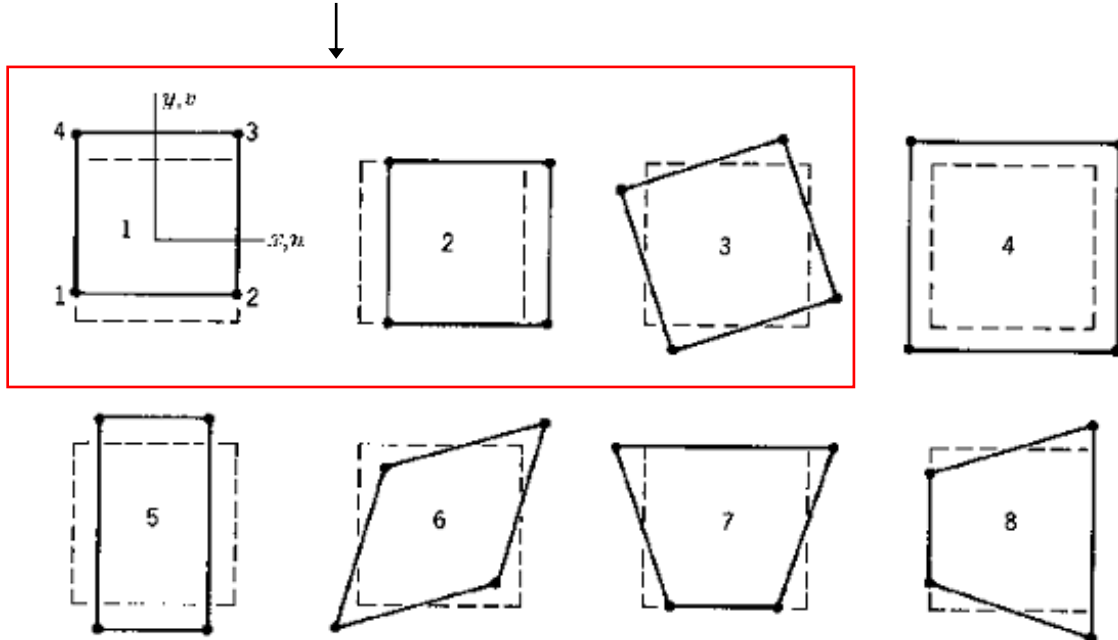

- Spurious Zero Energy Mode

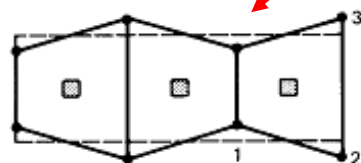
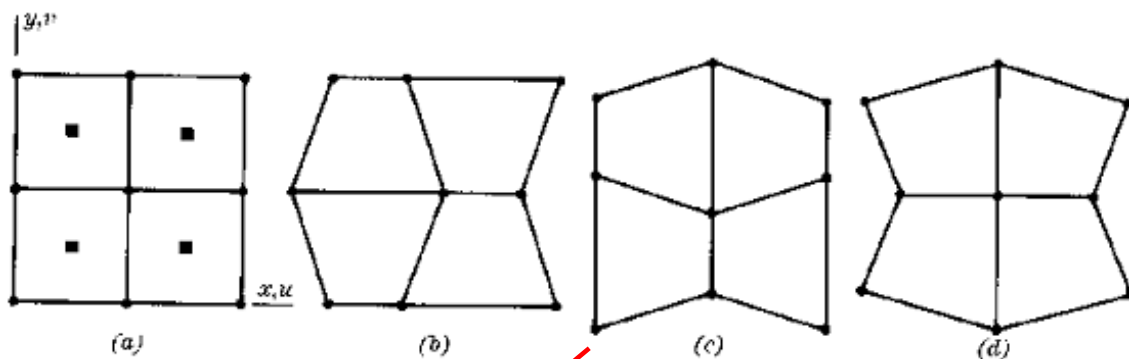

Hour glass mode



- Zero Energy mode of Q8 Element

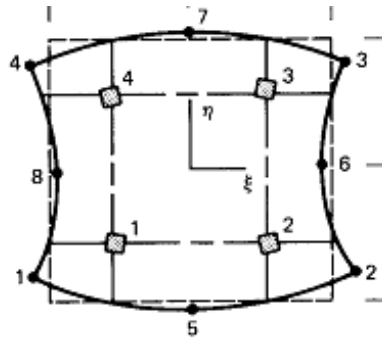

- Zero Energy Modes of Q9 Element

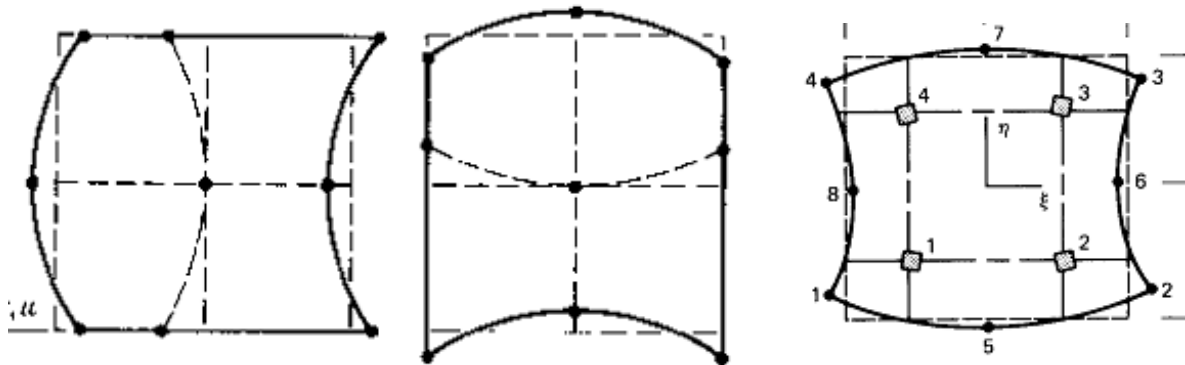

- Near Zero Energy Modes

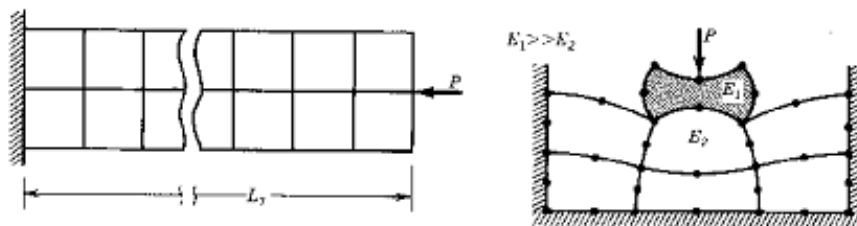

### 8.4. Selective Integration

$$\mathbf{D} = \frac{E(1-\nu)}{(1+\nu)(1-2\nu)} \begin{bmatrix} 1 & \frac{\nu}{1-\nu} & \frac{\nu}{1-\nu} & 0 & 0 & 0 \\ \frac{\nu}{1-\nu} & 1 & \frac{\nu}{1-\nu} & 0 & 0 & 0 \\ \frac{\nu}{1-\nu} & \frac{\nu}{1-\nu} & 1 & 0 & 0 & 0 \\ 0 & 0 & 0 & \frac{1-2\nu}{2(1-\nu)} & 0 & 0 \\ 0 & 0 & 0 & 0 & \frac{1-2\nu}{2(1-\nu)} & 0 \\ 0 & 0 & 0 & 0 & 0 & \frac{1-2\nu}{2(1-\nu)} \end{bmatrix} \\
 = \frac{E(1-\nu)}{(1+\nu)(1-2\nu)} \begin{bmatrix} 1 & \frac{\nu}{1-\nu} & \frac{\nu}{1-\nu} & 0 & 0 & 0 \\ \frac{\nu}{1-\nu} & 1 & \frac{\nu}{1-\nu} & 0 & 0 & 0 \\ \frac{\nu}{1-\nu} & \frac{\nu}{1-\nu} & 1 & 0 & 0 & 0 \\ 0 & 0 & 0 & 0 & 0 & 0 \\ 0 & 0 & 0 & 0 & 0 & 0 \\ 0 & 0 & 0 & 0 & 0 & 0 \end{bmatrix} + \frac{E}{2(1+\nu)} \begin{bmatrix} 0 & 0 & 0 & 0 & 0 & 0 \\ 0 & 0 & 0 & 0 & 0 & 0 \\ 0 & 0 & 0 & 0 & 0 & 0 \\ 0 & 0 & 0 & 1 & 0 & 0 \\ 0 & 0 & 0 & 0 & 1 & 0 \\ 0 & 0 & 0 & 0 & 0 & 1 \end{bmatrix} \\
 = \mathbf{D}_N + \mathbf{D}_S$$

$$\int_{V^e} \mathbf{B}^T \mathbf{D} \mathbf{B} dV = \int_{V^e} \mathbf{B}^T (\mathbf{D}_N + \mathbf{D}_S) \mathbf{B} dV = \underbrace{\int_{V^e} \mathbf{B}^T \mathbf{D}_N \mathbf{B} dV}_{\text{Full integration}} + \underbrace{\int_{V^e} \mathbf{B}^T \mathbf{D}_S \mathbf{B} dV}_{\text{Reduced integration}}$$

#### • Homework 8

Solve the cantilever beam problem in homework 6 for the end shear load case. Use 40 LST elements and 20 Q8 elements. For Q8 element, try the full and the reduced integration scheme. Compare your results including the displacement field and the stress field with those by CST elements and analytical solution.

This page is intentionally left blank.

# Chapter 9

## Convergence Criteria in the Isoparametric Element

- The interelement Continuity condition

This condition is satisfied because the geometry and the displacement field are defined uniquely on the interelement boundary with the coordinates and displacement field on the element boundary, respectively.

- The Completeness Condition

$$\phi(x, y) = \sum_i N_i \phi_i = a_0(\phi_k) + a_1(\phi_k)\xi + a_2(\phi_k)\eta + H(\xi, \eta, \phi_k)$$

$$x = \sum_i N_i x_i = a_0(x_k) + a_1(x_k)\xi + a_2(x_k)\eta + H(\xi, \eta, x_k)$$

$$y = \sum_i N_i y_i = a_0(y_k) + a_1(y_k)\xi + a_2(y_k)\eta + H(\xi, \eta, y_k)$$

$$\begin{Bmatrix} \xi \\ \eta \end{Bmatrix} = \frac{1}{|A|} \begin{bmatrix} a_2(y_k) & -a_2(x_k) \\ -a_1(y_k) & a_1(x_k) \end{bmatrix} \begin{Bmatrix} x - a_0(x_k) - H(\xi, \eta, x_k) \\ y - a_0(y_k) - H(\xi, \eta, y_k) \end{Bmatrix}$$

where  $|A| = a_1(x_k)a_2(y_k) - a_1(y_k)a_2(x_k)$

$$\phi(x, y) = a_0(\phi_k) -$$

$$\frac{a_1(\phi_k)}{|A|} (a_0(x_k)a_2(y_k) - a_0(y_k)a_2(x_k)) + \frac{a_2(\phi_k)}{|A|} (a_0(x_k)a_1(y_k) - a_0(y_k)a_1(x_k)) +$$

$$(a_1(\phi_k)a_2(y_k) - a_1(y_k)a_2(\phi_k)) \frac{x}{|A|} - (a_1(\phi_k)a_2(x_k) - a_1(x_k)a_2(\phi_k)) \frac{y}{|A|} + \text{H.O.T.}$$



# Chapter 10

## Miscellaneous Topics

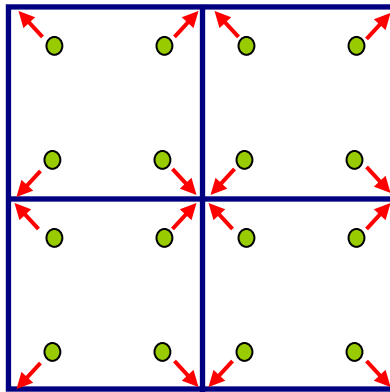

10.1 Stress Evaluation, Smoothing and Loubignac Iteration

10.2. Incompatible Element -  $Q_6$  and  $QM_6$

10.3. Static Condensation & Substructuring

10.4. Symmetry of Structure

10.5. Constraints in Discrete Problems

10.6. Constraints in Continuous Problems

## 10.1. Stress Evaluation, Smoothing and Loubignac Iteration

- **Stress evaluation**

- Stress components should be evaluated at the GP's in each element, not at nodes.
- The stress field is not uniquely determined on inter-element boundaries.

- **Stress smoothing at nodes**

- Continuous stress field can be obtained by extrapolating stresses at the GP's to nodes, and averaging them.
- The bilinear shape function or the Q9 shape function may be utilized for extrapolation of stress to nodes depending on the integration schemes.
- Mid-side nodes may be treated as either independent nodes or dependent nodes for the stress field

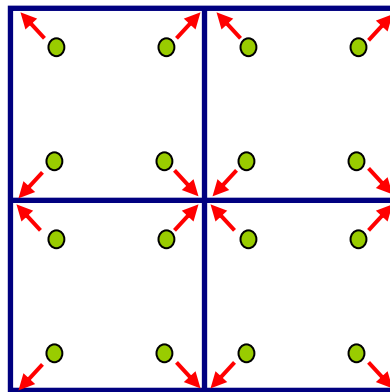

- **Loubignac iteration**

$$\sum_e \int_{V^e} \mathbf{B}^T \mathbf{D} \mathbf{B} dV \mathbf{U}^e = \sum_e \int_{V^e} \mathbf{N}^T \mathbf{b} dV + \sum_e \int_{\Gamma_i^e} \mathbf{N}^T \bar{\mathbf{T}} d\Gamma = \mathbf{F}$$

$$\sum_e \int_{V^e} \mathbf{B}^T \mathbf{D} \mathbf{B} dV \mathbf{U}^e = \sum_e \int_{V^e} \mathbf{B}^T \boldsymbol{\sigma} dV = \sum_e \int_{V^e} \mathbf{B}^T (\tilde{\boldsymbol{\sigma}} + \Delta \boldsymbol{\sigma}) dV = \sum_e \int_{V^e} \mathbf{B}^T \tilde{\boldsymbol{\sigma}} dV + \sum_e \int_{V^e} \mathbf{B}^T \mathbf{D} \mathbf{B} dV \Delta \mathbf{U}^e$$

$$\sum_e \int_{V^e} \mathbf{B}^T \mathbf{D} \mathbf{B} dV \Delta \mathbf{U}^e = \mathbf{F} - \sum_e \int_{V^e} \mathbf{B}^T \tilde{\boldsymbol{\sigma}} dV \rightarrow \mathbf{K} \Delta \mathbf{U}^e = \Delta \mathbf{F}$$

where  $\tilde{\boldsymbol{\sigma}}$  denotes the extrapolated and averaged stress field.

## 10.2. Incompatible Element - Q6



Deformed shape of Bilinear Element  
for pure bending

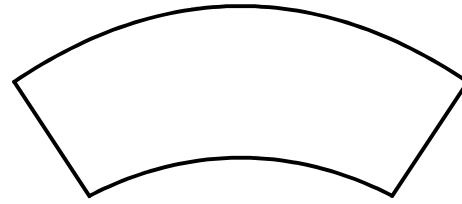

Correct deformed shape in pure bending

- **Behaviors of Bilinear Element for Pure Bending**

- Displacement field

$$u = \bar{u} \frac{1}{4} (1 - \xi)(1 - \eta) - \bar{u} \frac{1}{4} (1 + \xi)(1 - \eta) + \bar{u} \frac{1}{4} (1 + \xi)(1 + \eta) - \bar{u} \frac{1}{4} (1 - \xi)(1 + \eta) = \bar{u} \xi \eta$$

$$v = 0$$

- Strain & Stress field

$$\varepsilon_x = \frac{\partial u}{\partial x} = \eta \frac{\bar{u}}{a} = \frac{\bar{u}y}{ab}, \quad \varepsilon_y = \frac{\partial u}{\partial y} = 0, \quad \gamma_{xy} = \frac{\partial u}{\partial y} + \frac{\partial v}{\partial x} = \frac{\bar{u}x}{ab}$$

$$\sigma_x = \frac{E}{1 - \nu^2} \frac{\bar{u}y}{ab}, \quad \sigma_y = \frac{\nu E}{1 - \nu^2} \frac{\bar{u}y}{ab}, \quad \sigma_{xy} = \frac{E}{2(1 + \nu)} \frac{\bar{u}x}{ab}$$

- Strain Energy - Full Integration

$$\begin{aligned} \Pi_b &= \frac{1}{2} \int_{-a}^a \int_{-b}^b (\varepsilon_x \sigma_x + \varepsilon_y \sigma_y + \gamma_{xy} \sigma_{xy}) dy dx \\ &= \frac{1}{2} \int_{-a}^a \int_{-b}^b \left( \frac{E}{1 - \nu^2} \left( \frac{\bar{u}y}{ab} \right)^2 + \frac{E}{2(1 + \nu)} \left( \frac{\bar{u}x}{ab} \right)^2 \right) dy dx \\ &= \frac{1}{3} \frac{E}{1 - \nu^2} \left( 2 \frac{b}{a} + (1 - \nu) \frac{a}{b} \right) \bar{u}^2 \end{aligned}$$

- Strain Energy - Selective Integration

$$\begin{aligned} \Pi_b^s &= \frac{1}{2} \int_{-a}^a \int_{-b}^b \left( \frac{E}{1 - \nu^2} \left( \frac{\bar{u}y}{ab} \right)^2 + \frac{E}{2(1 + \nu)} \left( \frac{\bar{u}x}{ab} \right)^2 \right) dy dx \\ &= \frac{2}{3} \frac{E}{1 - \nu^2} \frac{b}{a} \bar{u} \end{aligned}$$

- **Real Behaviors for Pure Bending**

- Strain & Stress field

$$\sigma_x = ky, \quad \sigma_y = 0, \quad \sigma_{xy} = 0$$

$$\varepsilon_x = \frac{k}{E}y, \quad \varepsilon_y = -\frac{k\nu}{E}y, \quad \gamma_{xy} = 0$$

- Displacement field

$$u = \frac{k}{E}xy + f(y), \quad v = -\frac{1}{2}\frac{k\nu}{E}y^2 + g(x), \quad \gamma_{xy} = \frac{k}{E}x + f'(y) + g'(x) = 0$$

$$g'(x) + \frac{k}{E}x = -f'(y) = C, \quad g(x) = -\frac{1}{2}\frac{k}{E}x^2 + Cx + C_1, \quad f(y) = -Cy + C_2$$

$$u = \frac{k}{E}xy - Cy + C_2, \quad v = -\frac{1}{2}\frac{k\nu}{E}y^2 - \frac{1}{2}\frac{k}{E}x^2 + Cx + C_1$$

$$x = 0 \rightarrow u = -Cy + C_2 = 0 \rightarrow C = C_2 = 0$$

$$x = a, y = b \rightarrow u = \bar{u} \rightarrow k = \frac{E\bar{u}}{ab}$$

$C_1 = \text{Arbitrary}$

$$u = \frac{\bar{u}}{ab}xy, \quad v = -\frac{1}{2}\frac{\bar{u}\nu}{ab}y^2 - \frac{1}{2}\frac{\bar{u}}{ab}x^2 + C_1 = \left(1 - \left(\frac{x}{a}\right)^2\right)\frac{a\bar{u}}{2b} + \left(1 - \left(\frac{y}{b}\right)^2\right)\frac{b\bar{u}}{2a}$$

-Strain Energy – Exact Solution

$$\Pi_R = \frac{1}{2} \int_{-a-b}^a \int_{-a-b}^b (\varepsilon_x \sigma_x + \varepsilon_y \sigma_y + \gamma_{xy} \sigma_{xy}) dy dx = \frac{1}{2} \int_{-a-b}^a \int_{-a-b}^b E \left(\frac{\bar{u}y}{ab}\right)^2 dy dx = \frac{2}{3} E \frac{b}{a} \bar{u}^2$$

- **Ratio of strain Energy**

$$\frac{\Pi_b}{\Pi_R} = \frac{1}{1+\nu} \left( \frac{1}{1-\nu} + \frac{1}{2} \left(\frac{a}{b}\right)^2 \right), \quad \frac{\Pi_b^s}{\Pi_R} = \frac{1}{1-\nu^2} \approx 1.1 \text{ for } \nu = 0.3$$

The effect of parasitic shear becomes disastrous as the aspect ratio of bilinear element is large.

- **Q6 Incompatible Element**

- Shape function

$$u = \sum_i N_i^B u_i + a_1(1 - \xi^2) + a_2(1 - \eta^2)$$

$$v = \sum_i N_i^B v_i + a_3(1 - \xi^2) + a_4(1 - \eta^2)$$

$a_1, a_2, a_3, a_4$  are called as the “**nodeless degrees of freedom**”.

- Element Stiffnes Equation

$$\begin{bmatrix} K_{bb} & K_{bi} \\ K_{ib} & K_{ii} \end{bmatrix} \begin{pmatrix} (u) \\ (a) \end{pmatrix} = \begin{pmatrix} (f)^b \\ (f)^i \end{pmatrix}$$

- Static Condensation

$$[K_{ib}](u) + [K_{ii}](a) = (f)^i \rightarrow (a) = [K_{ii}]^{-1}((f)^i - [K_{ib}](u))$$

$$([K_{bb}] - [K_{bi}][K_{ii}]^{-1}[K_{ib}])(u) = (f)^b - [K_{ii}]^{-1}(f)^i \rightarrow [K^{Q6}](u) = (f^{Q6})$$

### 10.3. Static Condensation & Substructuring

- **Static Condensation:** *Eliminate some DOFs prior to a main analysis.*

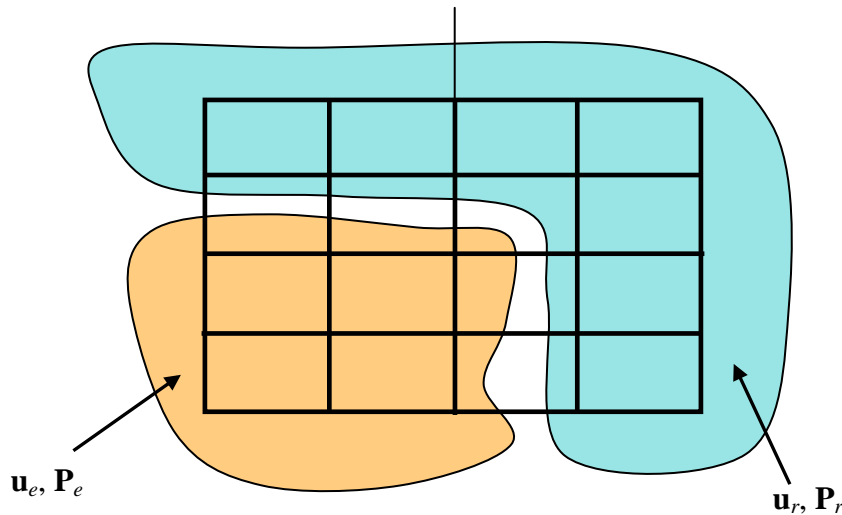

$$\begin{bmatrix} \mathbf{K}_{ee} & \mathbf{K}_{er} \\ \mathbf{K}_{re} & \mathbf{K}_{rr} \end{bmatrix} \begin{pmatrix} \mathbf{u}_e \\ \mathbf{u}_r \end{pmatrix} = \begin{pmatrix} \mathbf{P}_e \\ \mathbf{P}_r \end{pmatrix}$$

$$\mathbf{K}_{er}\mathbf{u}_r + \mathbf{K}_{ee}\mathbf{u}_e = \mathbf{P}_e \rightarrow \mathbf{u}_e = (\mathbf{K}_{ee})^{-1}(\mathbf{P}_e - \mathbf{K}_{er}\mathbf{u}_r)$$

$$\mathbf{K}_{rr}\mathbf{u}_r + \mathbf{K}_{re}\mathbf{u}_e = \mathbf{P}_r$$

$$\mathbf{K}_{rr}\mathbf{u}_r + \mathbf{K}_{re}(\mathbf{K}_{ee})^{-1}(\mathbf{P}_e - \mathbf{K}_{er}\mathbf{u}_r) = \mathbf{P}_r$$

$$\underline{(\mathbf{K}_{rr} - \mathbf{K}_{re}(\mathbf{K}_{ee})^{-1}\mathbf{K}_{er})\mathbf{u}_r = \mathbf{P}_r - \mathbf{K}_{re}(\mathbf{K}_{ee})^{-1}\mathbf{P}_e}$$

- From Gauss elimination point of view

$$\begin{bmatrix} \mathbf{K}_{ee} & \mathbf{K}_{er} \\ 0 & \mathbf{K}_{rr} - \mathbf{K}_{re}(\mathbf{K}_{ee})^{-1}\mathbf{K}_{er} \end{bmatrix} \begin{pmatrix} \mathbf{u}_e \\ \mathbf{u}_r \end{pmatrix} = \begin{pmatrix} \mathbf{P}_e \\ \mathbf{P}_r - \mathbf{K}_{re}(\mathbf{K}_{ee})^{-1}\mathbf{P}_e \end{pmatrix}$$

- **Substructuring**

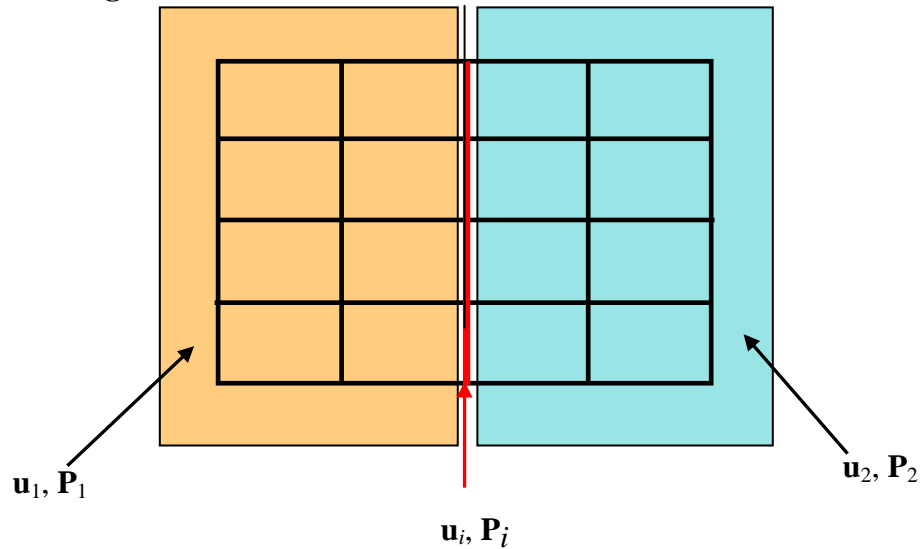

- Substructure 1

$$\begin{bmatrix} \mathbf{K}_{11} & \mathbf{K}_{1i} \\ \mathbf{K}_{i1} & \mathbf{K}_{ii}^1 \end{bmatrix} \begin{pmatrix} \mathbf{u}_1 \\ \mathbf{u}_i \end{pmatrix} = \begin{pmatrix} \mathbf{P}_1 \\ \mathbf{P}_i^1 \end{pmatrix}$$

$$\underline{(\mathbf{K}_{ii}^1 - \mathbf{K}_{i1}(\mathbf{K}_{11})^{-1}\mathbf{K}_{1i})\mathbf{u}_i = \mathbf{P}_i^1 - \mathbf{K}_{i1}(\mathbf{K}_{11})^{-1}\mathbf{P}_1}$$

- Substructure 2

$$\begin{bmatrix} \mathbf{K}_{22} & \mathbf{K}_{2i} \\ \mathbf{K}_{i2} & \mathbf{K}_{ii}^2 \end{bmatrix} \begin{pmatrix} \mathbf{u}_2 \\ \mathbf{u}_i \end{pmatrix} = \begin{pmatrix} \mathbf{P}_2 \\ \mathbf{P}_i^2 \end{pmatrix}$$

$$\underline{(\mathbf{K}_{ii}^2 - \mathbf{K}_{i2}(\mathbf{K}_{22})^{-1}\mathbf{K}_{2i})\mathbf{u}_i = \mathbf{P}_i^2 - \mathbf{K}_{i2}(\mathbf{K}_{22})^{-1}\mathbf{P}_2}$$

- Assembling

$$(\mathbf{K}_{ii}^1 + \mathbf{K}_{ii}^2 - \mathbf{K}_{i1}(\mathbf{K}_{11})^{-1}\mathbf{K}_{1i} - \mathbf{K}_{i2}(\mathbf{K}_{22})^{-1}\mathbf{K}_{2i})\mathbf{u}_i = \mathbf{P}_i^1 + \mathbf{P}_i^2 - \mathbf{K}_{i1}(\mathbf{K}_{11})^{-1}\mathbf{P}_1 - \mathbf{K}_{i2}(\mathbf{K}_{22})^{-1}\mathbf{P}_2$$

or

$$(\mathbf{K}_{ii}^1 + \mathbf{K}_{ii}^2 - \mathbf{K}_{i1}(\mathbf{K}_{11})^{-1}\mathbf{K}_{1i} - \mathbf{K}_{i2}(\mathbf{K}_{22})^{-1}\mathbf{K}_{2i})\mathbf{u}_i = \mathbf{P}_i - \mathbf{K}_{i1}(\mathbf{K}_{11})^{-1}\mathbf{P}_1 - \mathbf{K}_{i2}(\mathbf{K}_{22})^{-1}\mathbf{P}_2$$

- Partial Substructuring

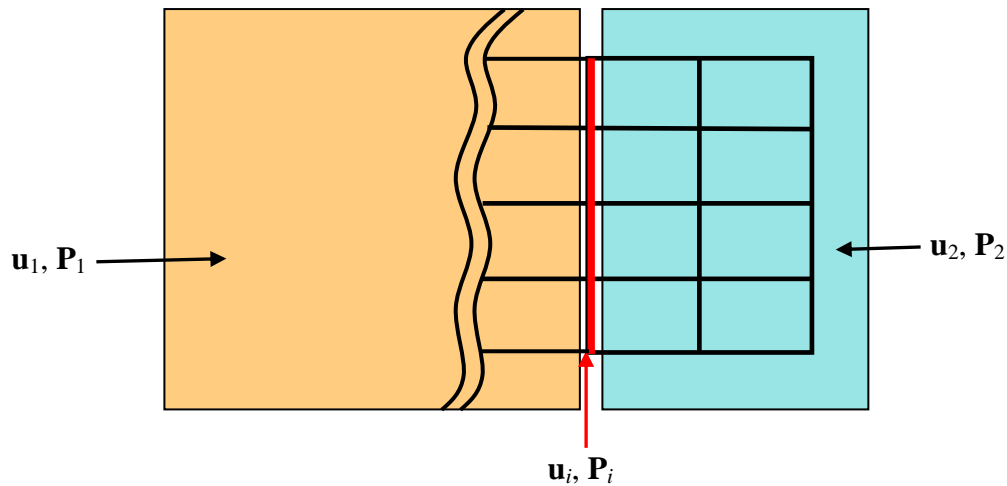

- Substructure 1

$$\begin{bmatrix} \mathbf{K}_{11} & \mathbf{K}_{1i} \\ \mathbf{K}_{i1} & \mathbf{K}_{ii}^1 \end{bmatrix} \begin{pmatrix} \mathbf{u}_1 \\ \mathbf{u}_i \end{pmatrix} = \begin{pmatrix} \mathbf{P}_1 \\ \mathbf{P}_i^1 \end{pmatrix}$$

$$\underline{(\mathbf{K}_{ii}^1 - \mathbf{K}_{i1}(\mathbf{K}_{11})^{-1}\mathbf{K}_{1i})\mathbf{u}_i = \mathbf{P}_i^1 - \mathbf{K}_{i1}(\mathbf{K}_{11})^{-1}\mathbf{P}_1}$$

- Substructure 2

$$\begin{bmatrix} \mathbf{K}_{22} & \mathbf{K}_{2i} \\ \mathbf{K}_{i2} & \mathbf{K}_{ii}^2 \end{bmatrix} \begin{pmatrix} \mathbf{u}_2 \\ \mathbf{u}_i \end{pmatrix} = \begin{pmatrix} \mathbf{P}_2 \\ \mathbf{P}_i^2 \end{pmatrix}$$

- Assembling

$$\begin{bmatrix} \mathbf{K}_{22} & \mathbf{K}_{2i} \\ \mathbf{K}_{i2} & \mathbf{K}_{ii}^2 + \mathbf{K}_{ii}^1 - \mathbf{K}_{i1}(\mathbf{K}_{11})^{-1}\mathbf{K}_{1i} \end{bmatrix} \begin{pmatrix} \mathbf{u}_2 \\ \mathbf{u}_i \end{pmatrix} = \begin{pmatrix} \mathbf{P}_2 \\ \mathbf{P}_i^1 + \mathbf{P}_i^2 - \mathbf{K}_{i1}(\mathbf{K}_{11})^{-1}\mathbf{P}_1 \end{pmatrix}$$

$\downarrow$   
 $\mathbf{P}_i$

### 10.4. Symmetry of Structure

- Symmetry

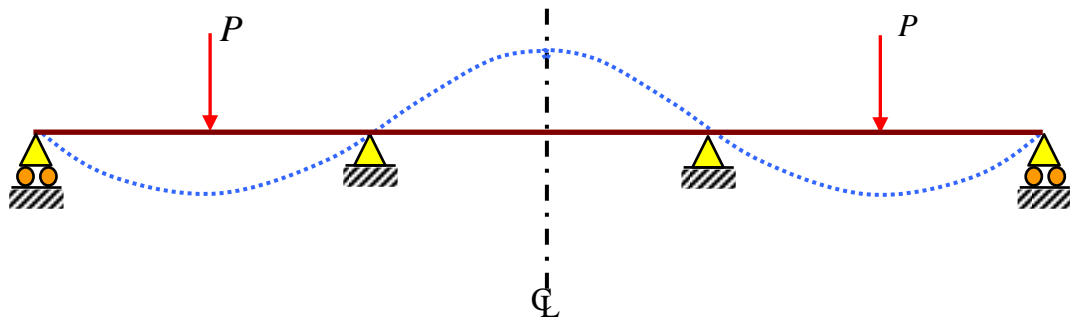

In plane displacement  $\neq 0$

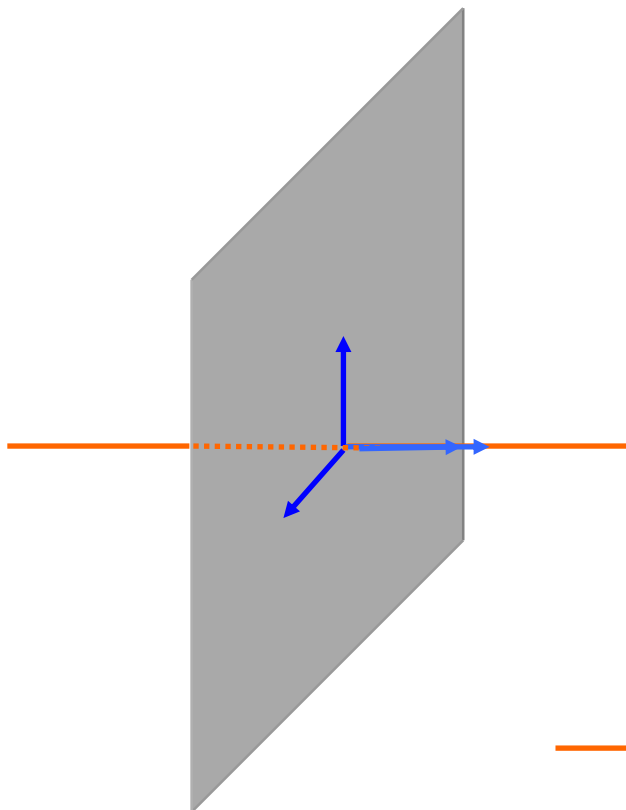

Out of plane displacement = 0

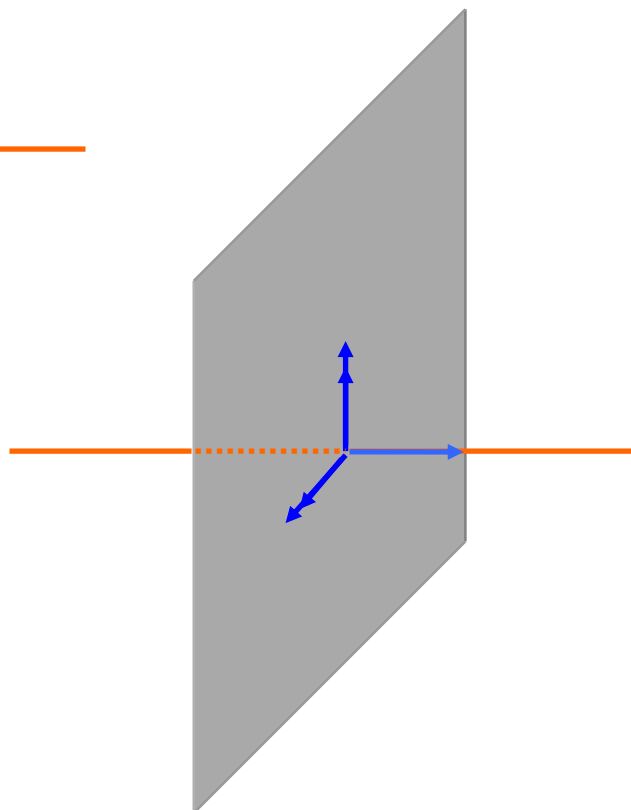



- **Anti-Symmetry**

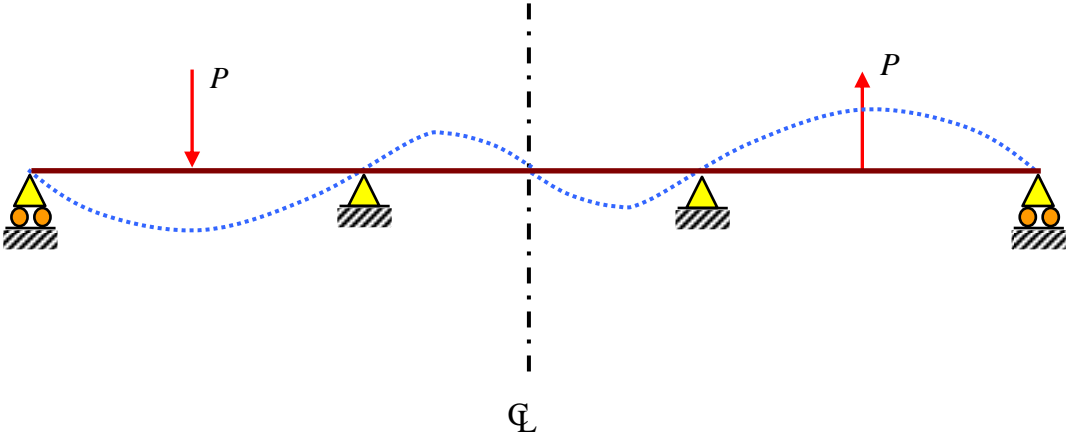

In plane displacement = 0

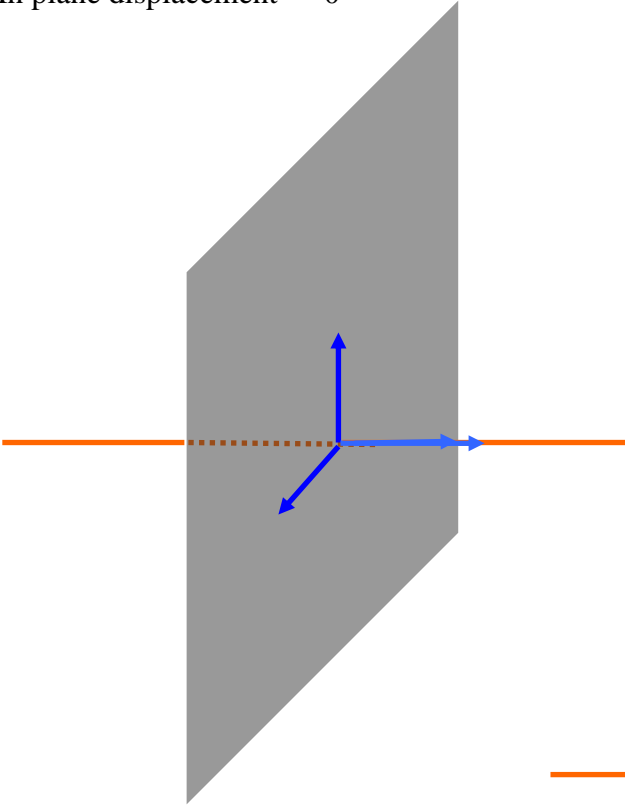

Out of plane displacement  $\neq 0$

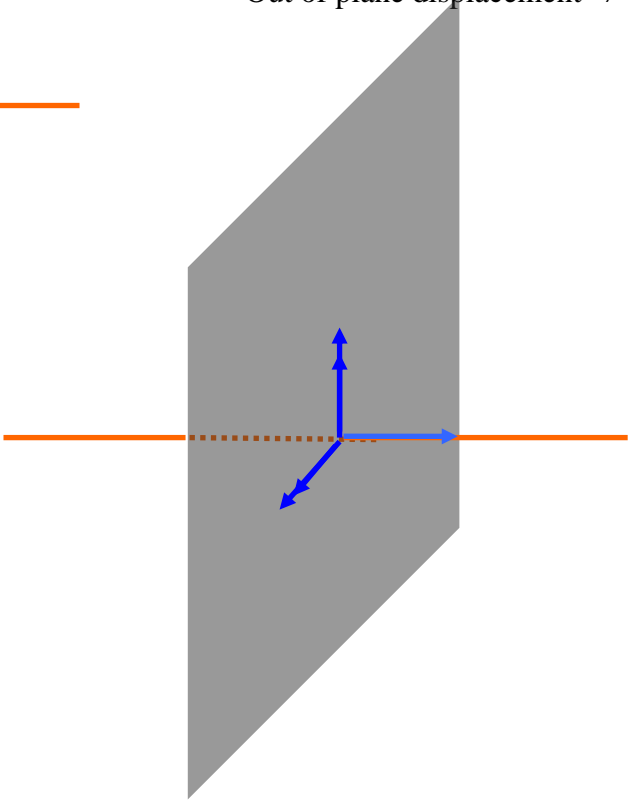

- Symmetric structures with Non-Symmetric loading

- General loading



- Symmetric loading



- Antisymmetric loading



$$\begin{pmatrix} \mathbf{P}_1 \\ \mathbf{P}_2 \end{pmatrix} = \begin{pmatrix} \mathbf{P}_S \\ \mathbf{P}_S \end{pmatrix} + \begin{pmatrix} \mathbf{P}_A \\ -\mathbf{P}_A \end{pmatrix} \rightarrow \begin{cases} \mathbf{P}_S = \frac{\mathbf{P}_1 + \mathbf{P}_2}{2} \\ \mathbf{P}_A = \frac{\mathbf{P}_1 - \mathbf{P}_2}{2} \end{cases}$$

- Cyclic Symmetry

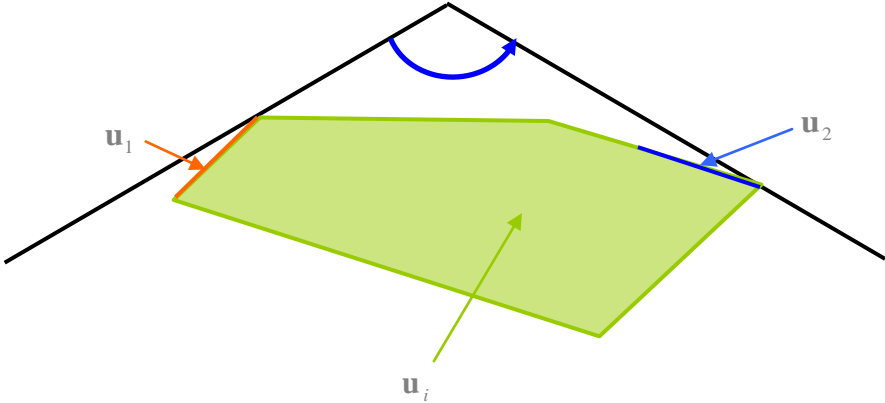
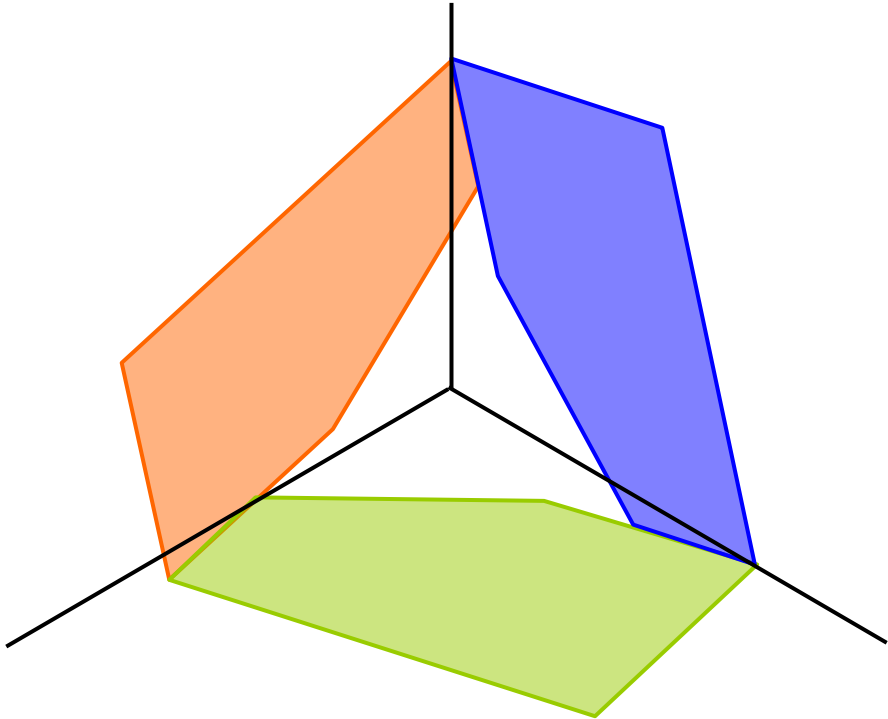

- Structural Resistance force in a segment

$$\begin{pmatrix} \mathbf{F}_1 \\ \mathbf{F}_i \\ \mathbf{F}_2 \end{pmatrix} = \begin{bmatrix} \mathbf{K}_{11} & \mathbf{K}_{1i} & \mathbf{K}_{12} \\ \mathbf{K}_{i1} & \mathbf{K}_{ii} & \mathbf{K}_{i2} \\ \mathbf{K}_{21} & \mathbf{K}_{2i} & \mathbf{K}_{22} \end{bmatrix} \begin{pmatrix} \mathbf{u}_1 \\ \mathbf{u}_i \\ \mathbf{u}_2 \end{pmatrix}$$

- Compatibility

$$\mathbf{u}_1 = \Gamma \mathbf{u}_2$$

$$\begin{pmatrix} \mathbf{u}_1 \\ \mathbf{u}_i \\ \mathbf{u}_2 \end{pmatrix} = \begin{bmatrix} \mathbf{0} & \Gamma \\ \mathbf{I} & \mathbf{0} \\ \mathbf{0} & \mathbf{I} \end{bmatrix} \begin{pmatrix} \mathbf{u}_i \\ \mathbf{u}_2 \end{pmatrix}$$

- Equilibrium

$$\begin{aligned} \mathbf{P}_i &= \mathbf{F}_i \\ \mathbf{P}_2 &= \mathbf{F}_2 + \Gamma^T \mathbf{F}_1 \end{aligned} \rightarrow \begin{pmatrix} \mathbf{P}_i \\ \mathbf{P}_2 \end{pmatrix} = \begin{bmatrix} \mathbf{0} & \mathbf{I} & \mathbf{0} \\ \Gamma^T & \mathbf{0} & \mathbf{I} \end{bmatrix} \begin{pmatrix} \mathbf{F}_1 \\ \mathbf{F}_i \\ \mathbf{F}_2 \end{pmatrix}$$

$$\begin{pmatrix} \mathbf{P}_i \\ \mathbf{P}_2 \end{pmatrix} = \begin{bmatrix} \mathbf{0} & \mathbf{I} & \mathbf{0} \\ \Gamma^T & \mathbf{0} & \mathbf{I} \end{bmatrix} \begin{bmatrix} \mathbf{K}_{11} & \mathbf{K}_{1i} & \mathbf{K}_{12} \\ \mathbf{K}_{i1} & \mathbf{K}_{ii} & \mathbf{K}_{i2} \\ \mathbf{K}_{21} & \mathbf{K}_{2i} & \mathbf{K}_{22} \end{bmatrix} \begin{bmatrix} \mathbf{0} & \Gamma \\ \mathbf{I} & \mathbf{0} \\ \mathbf{0} & \mathbf{I} \end{bmatrix} \begin{pmatrix} \mathbf{u}_i \\ \mathbf{u}_2 \end{pmatrix}$$

- Final Equation

$$\begin{pmatrix} \mathbf{P}_i \\ \mathbf{P}_2 \end{pmatrix} = \begin{bmatrix} \mathbf{0} & \mathbf{I} & \mathbf{0} \\ \Gamma^T & \mathbf{0} & \mathbf{I} \end{bmatrix} \begin{bmatrix} \mathbf{K}_{1i} & \mathbf{K}_{11}\Gamma + \mathbf{K}_{12} \\ \mathbf{K}_{ii} & \mathbf{K}_{i1}\Gamma + \mathbf{K}_{i2} \\ \mathbf{K}_{2i} & \mathbf{K}_{21}\Gamma + \mathbf{K}_{22} \end{bmatrix} \begin{pmatrix} \mathbf{u}_i \\ \mathbf{u}_2 \end{pmatrix}$$

$$= \begin{bmatrix} \mathbf{K}_{ii} & \mathbf{K}_{i1}\Gamma + \mathbf{K}_{i2} \\ \Gamma^T \mathbf{K}_{1i} + \mathbf{K}_{2i} & \Gamma^T \mathbf{K}_{11}\Gamma + \Gamma^T \mathbf{K}_{12} + \mathbf{K}_{21}\Gamma + \mathbf{K}_{22} \end{bmatrix} \begin{pmatrix} \mathbf{u}_i \\ \mathbf{u}_2 \end{pmatrix}$$

## 10.5. Constraints in Discrete Problems

- **Minimization Problem**

$$\underset{\mathbf{U}}{\text{Min}} \Pi = \frac{1}{2} \mathbf{U}^T \mathbf{K} \mathbf{U} - \mathbf{U}^T \mathbf{P} \quad \text{subject to} \quad \mathbf{A}(\mathbf{U}) = \mathbf{0}$$

$$\mathbf{U} = \begin{pmatrix} \mathbf{U}_f \\ \mathbf{U}_r \end{pmatrix}, \quad \mathbf{K} = \begin{bmatrix} \mathbf{K}_{ff} & \mathbf{K}_{fr} \\ \mathbf{K}_{rf} & \mathbf{K}_{rr} \end{bmatrix}, \quad \mathbf{P} = \begin{pmatrix} \mathbf{P}_f \\ \mathbf{P}_r \end{pmatrix}$$

- **1<sup>st</sup> order Optimality condition**

$$\frac{\partial \Pi}{\partial \mathbf{U}} = 0 \quad \rightarrow \quad \mathbf{K} \mathbf{U} - \mathbf{P} = 0$$

- **Usual homogenous support conditions**

$$\mathbf{U}_r = 0$$

$$\underset{\mathbf{U}_f}{\text{Min}} \Pi = \frac{1}{2} \mathbf{U}_f^T \mathbf{K}_f \mathbf{U}_f - \mathbf{U}_f^T \mathbf{P}_f \quad \rightarrow \quad \mathbf{K}_f \mathbf{U}_f = \mathbf{P}_f$$

- **Non-homogenous support conditions (support Settlement)**

$$\mathbf{U}_r = \bar{\mathbf{U}}_r$$

$$\begin{aligned} \Pi &= \frac{1}{2} (\mathbf{U}_f^T \mathbf{K}_{ff} \mathbf{U}_f + \bar{\mathbf{U}}_r^T \mathbf{K}_{rf} \mathbf{U}_f + \mathbf{U}_f^T \mathbf{K}_{fr} \bar{\mathbf{U}}_r + \bar{\mathbf{U}}_r^T \mathbf{K}_{rr} \bar{\mathbf{U}}_r) - \mathbf{U}_f^T \mathbf{P}_f - \bar{\mathbf{U}}_r^T \mathbf{P}_r \\ &= \frac{1}{2} (\mathbf{U}_f^T \mathbf{K}_{ff} \mathbf{U}_f + 2 \mathbf{U}_f^T \mathbf{K}_{fr} \bar{\mathbf{U}}_r + \bar{\mathbf{U}}_r^T \mathbf{K}_{rr} \bar{\mathbf{U}}_r) - \mathbf{U}_f^T \mathbf{P}_f - \bar{\mathbf{U}}_r^T \mathbf{P}_r \end{aligned}$$

$$\underset{\mathbf{U}_f}{\text{Min}} \Pi = \underset{\mathbf{U}_f}{\text{Min}} \Pi \rightarrow \mathbf{K}_{ff} \mathbf{U}_f + \mathbf{K}_{fr} \bar{\mathbf{U}}_r - \mathbf{P}_f = 0$$

$$\mathbf{K}_{ff} \mathbf{U}_f = \mathbf{P}_f - \mathbf{K}_{fr} \bar{\mathbf{U}}_r$$

or

$$\delta \Pi = \frac{\partial \Pi}{\partial \mathbf{U}} \delta \mathbf{U} = \frac{\partial \Pi}{\partial \mathbf{U}_f} \delta \mathbf{U}_f + \frac{\partial \Pi}{\partial \mathbf{U}_r} \delta \mathbf{U}_r = \frac{\partial \Pi}{\partial \mathbf{U}_f} \delta \mathbf{U}_f = 0 \rightarrow \frac{\partial \Pi}{\partial \mathbf{U}_f} = 0$$

- **General Non-homogenous Linear Constraints**

$$\mathbf{A}(\mathbf{U}) = \mathbf{R} \mathbf{U} - \mathbf{r}_0 = 0 \rightarrow \sum_{j=1}^{ndof} r_{ij} u_j = r_{i0}, \quad i = 1, \dots, ncon$$

$$\mathbf{R} \mathbf{U} = \mathbf{R}_r \mathbf{U}_r + \mathbf{R}_f \mathbf{U}_f = \mathbf{r}_0 \rightarrow \mathbf{U}_r = -\mathbf{R}_r^{-1} \mathbf{R}_f \mathbf{U}_f + \mathbf{R}_r^{-1} \mathbf{r}_0 = \mathbf{C} \mathbf{U}_f + \mathbf{C}_0$$

$$\mathbf{U} = \begin{pmatrix} \mathbf{U}_f \\ \mathbf{U}_r \end{pmatrix} = \begin{pmatrix} \mathbf{I} \\ \mathbf{C} \end{pmatrix} \mathbf{U}_f + \begin{pmatrix} \mathbf{0} \\ \mathbf{C}_0 \end{pmatrix}$$

$$\begin{aligned}
\Pi &= \frac{1}{2} \mathbf{U}^T \mathbf{K} \mathbf{U} - \mathbf{U}^T \mathbf{P} \\
&= \frac{1}{2} \mathbf{U}_f^T [\mathbf{K}_{ff} + \mathbf{K}_{fr} \mathbf{C} + \mathbf{C}^T \mathbf{K}_{rf} + \mathbf{C}^T \mathbf{K}_{rr} \mathbf{C}] \mathbf{U}_f \\
&\quad + \mathbf{U}_f^T (\mathbf{K}_{fr} \mathbf{C}_0 + \mathbf{C}^T \mathbf{K}_{rr} \mathbf{C}_0) + \frac{1}{2} \mathbf{C}_0^T \mathbf{K}_{rr} \mathbf{C}_0 - \mathbf{U}_f^T (\mathbf{P}_f + \mathbf{C}^T \mathbf{P}_r) \\
[\mathbf{K}_{ff} + \mathbf{K}_{fr} \mathbf{C} + \mathbf{C}^T \mathbf{K}_{rf} + \mathbf{C}^T \mathbf{K}_{rr} \mathbf{C}] \mathbf{U}_f &= (\mathbf{P}_f + \mathbf{C}^T \mathbf{P}_r) - (\mathbf{K}_{fr} \mathbf{C}_0 + \mathbf{C}^T \mathbf{K}_{rr} \mathbf{C}_0)
\end{aligned}$$

- **Lagrange Multiplier**

$$\begin{aligned}
\text{Min}_{\mathbf{U}, \boldsymbol{\lambda}} \bar{\Pi} &= \frac{1}{2} \mathbf{U}^T \mathbf{K} \mathbf{U} - \mathbf{U}^T \mathbf{P} + \boldsymbol{\lambda}^T (\mathbf{R} \mathbf{U} - \mathbf{r}_0) \rightarrow \frac{\partial \bar{\Pi}}{\partial \mathbf{U}} = 0, \quad \frac{\partial \bar{\Pi}}{\partial \boldsymbol{\lambda}} = 0 \\
\left. \begin{aligned} \frac{\partial \bar{\Pi}}{\partial \mathbf{U}} &= \mathbf{K} \mathbf{U} - \mathbf{P} + \boldsymbol{\lambda}^T \frac{\partial \mathbf{A}(\mathbf{U})}{\partial \mathbf{U}} = \mathbf{K} \mathbf{U} - \mathbf{P} + \boldsymbol{\lambda}^T \mathbf{R} = 0 \\ \frac{\partial \bar{\Pi}}{\partial \boldsymbol{\lambda}} &= \mathbf{A}(\mathbf{U}) = \mathbf{R} \mathbf{U} - \mathbf{r}_0 = 0 \end{aligned} \right\} \rightarrow \begin{bmatrix} \mathbf{K} & \mathbf{R}^T \\ \mathbf{R} & \mathbf{0} \end{bmatrix} \begin{pmatrix} \mathbf{U} \\ \boldsymbol{\lambda} \end{pmatrix} = \begin{pmatrix} \mathbf{P} \\ \mathbf{r}_0 \end{pmatrix}
\end{aligned}$$

$$\mathbf{K} \mathbf{U} - \mathbf{P} + \mathbf{R}^T \boldsymbol{\lambda} = 0 \rightarrow \mathbf{U} = \mathbf{K}^{-1} (\mathbf{P} - \mathbf{R}^T \boldsymbol{\lambda})$$

$$\mathbf{R} \mathbf{U} - \mathbf{r}_0 = \mathbf{R} \mathbf{K}^{-1} (\mathbf{P} - \mathbf{R}^T \boldsymbol{\lambda}) - \mathbf{r}_0 = 0 \rightarrow \boldsymbol{\lambda} = (\mathbf{R} \mathbf{K}^{-1} \mathbf{R}^T)^{-1} (\mathbf{R} \mathbf{K}^{-1} \mathbf{P} - \mathbf{r}_0)$$

$$\begin{aligned}
\mathbf{U} &= \mathbf{K}^{-1} (\mathbf{P} - \mathbf{R}^T (\mathbf{R} \mathbf{K}^{-1} \mathbf{R}^T)^{-1} (\mathbf{R} \mathbf{K}^{-1} \mathbf{P} - \mathbf{r}_0)) \\
&= (\mathbf{K}^{-1} - \mathbf{K}^{-1} \mathbf{R}^T (\mathbf{R} \mathbf{K}^{-1} \mathbf{R}^T)^{-1} \mathbf{R} \mathbf{K}^{-1}) \mathbf{P} + \mathbf{K}^{-1} \mathbf{R}^T (\mathbf{R} \mathbf{K}^{-1} \mathbf{R}^T)^{-1} \mathbf{r}_0
\end{aligned}$$

## 10.6. Constraints in Continuous Problems

- **Lagrange Multiplier**

$$\text{Min}_{\mathbf{u}} \Pi \quad \text{subject to} \quad \mathbf{A}(\mathbf{u}) = \mathbf{0}$$

where  $\Pi$  is the original functional derived from the minimization principle or equivalent, and  $\mathbf{A}(\mathbf{u}) = \mathbf{0}$  denotes an additional set of constraints, which may be defined in some volume, on some surface, or at some points. For the simplicity of derivation, only constraints specified along a surface is considered in this note.

$$\mathbf{A}(\mathbf{u}) = \mathbf{L} \mathbf{u} - \mathbf{r}_0 = 0 \quad \text{on } S$$

$$\begin{aligned}
\text{Min}_{u_i, \boldsymbol{\lambda}} \bar{\Pi}(u_i, \boldsymbol{\lambda}) &= \Pi(u) + \int_S \boldsymbol{\lambda} (\mathbf{L} \mathbf{u} - \mathbf{r}_0) dS \\
&= \frac{1}{2} \int_V \varepsilon_{ij}^h \sigma_{ij}^h dV - \int_V u_i^h b_i dV - \int_{S_i} u_i^h \bar{T}_i dS + \int_S \boldsymbol{\lambda} (\mathbf{L} \mathbf{u} - \mathbf{r}_0) dS
\end{aligned}$$

By discretizing  $\lambda = \bar{\mathbf{N}}\boldsymbol{\Lambda}^e$  in an element and the displacement field in usual way,

$$\begin{aligned}\bar{\Pi}(u_i, \lambda) &\approx \frac{1}{2} \mathbf{U}^T \mathbf{K} \mathbf{U} - \mathbf{U}^T \mathbf{f} + \sum_e (\boldsymbol{\Lambda}^e)^T \int_{S_e} \bar{\mathbf{N}}^T \mathbf{L} \mathbf{N} dS \mathbf{U}^e - \sum_e (\boldsymbol{\Lambda}^e)^T \int_{S_e} \bar{\mathbf{N}}^T \mathbf{r}_0 dS \\ &= \frac{1}{2} \mathbf{U}^T \mathbf{K} \mathbf{U} - \mathbf{U}^T \mathbf{f} + \boldsymbol{\Lambda}^T \int_{S_e} \bar{\mathbf{N}}^T \mathbf{L} \mathbf{N} dS \mathbf{U} - \boldsymbol{\Lambda}^T \int_{S_e} \bar{\mathbf{N}}^T \mathbf{r}_0 dS \\ &= \frac{1}{2} \mathbf{U}^T \mathbf{K} \mathbf{U} - \mathbf{U}^T \mathbf{f} + \boldsymbol{\Lambda}^T \mathbf{R} \mathbf{U} - \boldsymbol{\Lambda}^T \mathbf{q}\end{aligned}$$

Therefore, the stationary condition for modified energy functional becomes

$$\left. \begin{aligned}\frac{\partial \bar{\Pi}}{\partial \mathbf{U}} &= \mathbf{K} \mathbf{U} - \mathbf{f} + \mathbf{R}^T \boldsymbol{\Lambda} = 0 \\ \frac{\partial \bar{\Pi}}{\partial \boldsymbol{\Lambda}} &= \mathbf{R} \mathbf{U} - \mathbf{q} = 0\end{aligned}\right\} \rightarrow \begin{bmatrix} \mathbf{K} & \mathbf{R}^T \\ \mathbf{R} & \mathbf{0} \end{bmatrix} \begin{pmatrix} \mathbf{U} \\ \boldsymbol{\Lambda} \end{pmatrix} = \begin{pmatrix} \mathbf{f} \\ \mathbf{q} \end{pmatrix}$$

The solution procedure from this point is exactly the same as that of discrete problems. *The last and the most important question is what kind of interpolation function has to be employed for the Lagrange multiplier.*

- **Penalty Function**

$$\begin{aligned}\text{Min}_u \bar{\Pi}(\mathbf{u}) &= \Pi(\mathbf{u}) + \frac{\alpha}{2} \int_S \mathbf{A}^T(\mathbf{u}) \cdot \mathbf{A}(\mathbf{u}) dS \\ \bar{\Pi}(\mathbf{u}) &\approx \frac{1}{2} \int_V \varepsilon_{ij}^h \sigma_{ij}^h dV - \int_V u_i^h b_i dV - \int_{S_i} u_i^h \bar{T}_i dS + \frac{\alpha}{2} \int_S (\mathbf{L} \mathbf{u} - \mathbf{r}_0)^T (\mathbf{L} \mathbf{u} - \mathbf{r}_0) dS \\ &= \frac{1}{2} \mathbf{U}^T \mathbf{K} \mathbf{U} - \mathbf{U}^T \mathbf{f} + \frac{\alpha}{2} \sum_e \{ (\mathbf{U}^e)^T \int_{S_e} (\mathbf{L} \mathbf{N})^T \mathbf{L} \mathbf{N} dS \mathbf{U}^e - 2 (\mathbf{U}^e)^T \int_{S_e} (\mathbf{L} \mathbf{N})^T \mathbf{r}_0 dS + \int_{S_e} \mathbf{r}_0^T \mathbf{r}_0 dS \} \\ &= \frac{1}{2} \mathbf{U}^T \mathbf{K} \mathbf{U} - \mathbf{U}^T \mathbf{f} + \frac{\alpha}{2} (\mathbf{U}^T \mathbf{K}_R \mathbf{U} - 2 \mathbf{U}^T \mathbf{q} + \mathbf{C})\end{aligned}$$

$$\text{Min}_u \bar{\Pi}(\mathbf{u}) \rightarrow \frac{\partial \bar{\Pi}}{\partial \mathbf{U}} = 0 \rightarrow (\mathbf{K} + \alpha \mathbf{K}_R) \mathbf{U} = \mathbf{f} + \alpha \mathbf{q}$$

This page is intentionally left blank.



# Chapter 11

## Problems with Higher Continuity Requirement – Beams –

$$\nabla^4 = ??$$

11.1. C Formulation

11.2. C° Formulation

11.3. Timoshenko Beam

## 11.1. C<sup>1</sup>-Formulation

- **Governing Equation**

$$EI \frac{d^4 w}{dx^4} = q$$

- **Weak Form of the governing equation**

$$\int_0^l \hat{w} \left( EI \frac{d^4 w}{dx^4} - q \right) dx = 0 \quad \text{for all admissible } \hat{w}$$

$$\hat{w} EI \frac{d^3 w}{dx^3} \Big|_0^l - \frac{d\hat{w}}{dx} EI \frac{d^2 w}{dx^2} \Big|_0^l + \int_0^l \frac{d^2 \hat{w}}{dx^2} EI \frac{d^2 w}{dx^2} dx - \int_0^l \hat{w} q dx = 0$$

$$\int_0^l \frac{d^2 \hat{w}}{dx^2} EI \frac{d^2 w}{dx^2} dx = \int_0^l \hat{w} q dx + \hat{w} V \Big|_0^l - \hat{\theta} M \Big|_0^l \rightarrow \int_0^l \frac{d^2 \hat{w}}{dx^2} EI \frac{d^2 w}{dx^2} dx = \int_0^l \hat{w} q dx$$

- **Continuity Requirement**

The second derivative of the displacement field has to be piecewise-continuous for the valid finite element formulation. Therefore,  $w$  has to be continuous up to the first derivatives.

$$\int_0^l \frac{d^2 \hat{w}}{dx^2} EI \frac{d^2 w}{dx^2} dx = \sum_e \int_{l^e} \frac{d^2 \hat{w}}{dx^2} EI \frac{d^2 w}{dx^2} dx$$

- **Hermitian Shape Functions**

$$w = N_1 w_l + N_2 \theta_l + N_3 w_r + N_4 \theta_r$$

$$\text{where } w_l = w(0), \theta_l = \frac{dw}{dx} \Big|_{x=0}, w_r = w(l_e), \theta_r = \frac{dw}{dx} \Big|_{x=l_e}$$

$$N_1 = 1 - 3 \frac{x^2}{l_e^2} + 2 \frac{x^3}{l_e^3}, \quad N_2 = x - 2 \frac{x^2}{l_e} + \frac{x^3}{l_e^2}$$

$$N_3 = 3 \frac{x^2}{l_e^2} - 2 \frac{x^3}{l_e^3}, \quad N_4 = -\frac{x^2}{l_e} + \frac{x^3}{l_e^2}$$

## 11.2. $C^0$ -Formulation

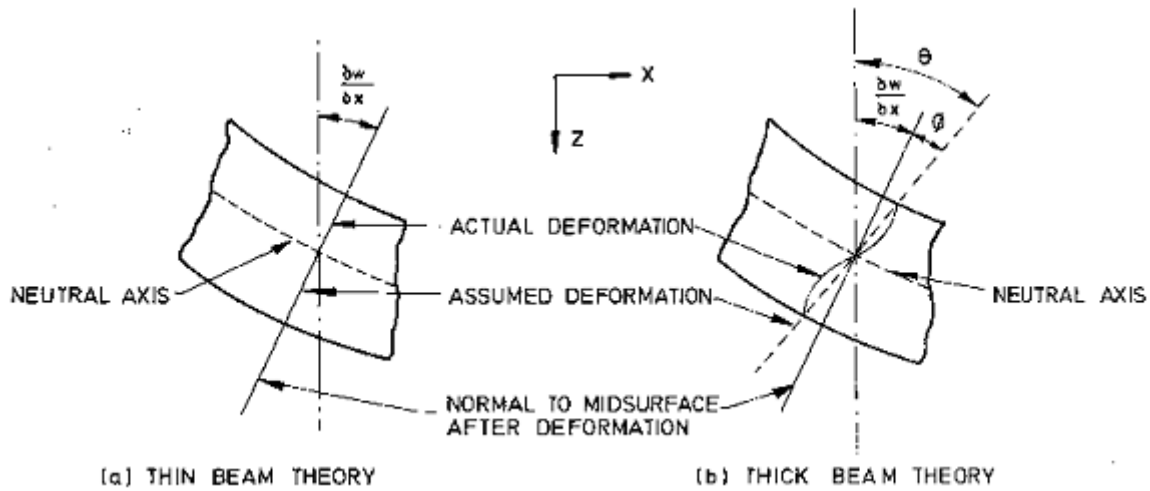

### • Energy Consideration

$w$ : total deflection,  $\theta$ : rotation,  $\frac{dw}{dx} - \theta$ : shear deformation

$$\Pi = \frac{1}{2} \left( \int_0^l \frac{d\theta}{dx} EI \frac{d\theta}{dx} dx + \int_0^l \left( \frac{dw}{dx} - \theta \right) GA_0 \left( \frac{dw}{dx} - \theta \right) dx \right) - \int_0^l w q dx$$

$$w = \sum_i N_i w_i, \quad \theta = \sum_i N_i \theta_i$$

$$\rightarrow \Delta^e = [w_1 \quad \theta_1 \quad w_2 \quad \theta_2 \quad \cdots \quad w_n \quad \theta_n]^T$$

$$\frac{d\theta}{dx} = \sum_i \frac{dN_i}{dx} \theta_i = \left[ 0 \quad \frac{dN_1}{dx} \quad 0 \quad \frac{dN_2}{dx} \cdots 0 \quad \frac{dN_n}{dx} \right] (\Delta^e) = \mathbf{B}_M \Delta^e$$

$$\frac{dw}{dx} - \theta = \sum_i \frac{dN_i}{dx} w_i - \sum_i N_i \theta_i = \left[ \frac{dN_1}{dx} \quad -N_1 \quad \frac{dN_2}{dx} \quad -N_2 \quad \cdots \quad \frac{dN_n}{dx} \quad -N_n \right] \Delta^e = \mathbf{B}_S \Delta^e$$

$$w = [N_1 \quad 0 \quad N_2 \quad 0 \cdots N_n \quad 0] \Delta^e$$

$$\Pi = \frac{1}{2} \sum_e (\Delta^e)^T \left( \int_0^{l_e} \mathbf{B}_M^T EI \mathbf{B}_M dx + \int_0^{l_e} \mathbf{B}_S^T GA_0 \mathbf{B}_S dx \right) \Delta^e - \sum_e (\Delta^e)^T \int_0^{l_e} [\mathbf{N}] q dx$$

$$= \frac{1}{2} \sum_e (\Delta^e)^T (\mathbf{K}_M^e + \mathbf{K}_S^e) \Delta^e - \sum_e (\Delta^e)^T \mathbf{f}^e$$

$$= \frac{1}{2} \Delta^T (\mathbf{K}_M + \mathbf{K}_S) \Delta - \Delta^T \mathbf{f}^e = \frac{1}{2} \Delta^T \mathbf{K} \Delta - \Delta^T \mathbf{f}^e$$

$$\frac{\partial \Pi}{\partial \Delta} = \mathbf{K} \Delta - \mathbf{f}^e = 0$$

- **Problems –Functions Space Interlocking**

$$\frac{\Pi}{EI} = \frac{1}{2} \left( \int_0^l \frac{d\theta}{dx} \frac{d\theta}{dx} dx + \frac{GA_0 l^2}{EI} \frac{1}{l^2} \int_0^l \left( \frac{dw}{dx} - \theta \right) \left( \frac{dw}{dx} - \theta \right) dx \right) - \int_0^l \frac{wq}{EI} dx$$

$$\lambda = \frac{GA_0 l^2}{EI} = \frac{6\kappa}{(1+\nu)} \frac{l^2}{t^2} \text{ for rectangular beam.}$$

$$\text{As } \lambda \rightarrow \infty, \frac{1}{l^2} \int_0^l \left( \frac{dw}{dx} - \theta \right) \left( \frac{dw}{dx} - \theta \right) dx \rightarrow 0 \text{ or } \frac{dw}{dx} \equiv \theta \text{ to keep the total potential energy}$$

finite. This condition may be satisfied in case the entire, exact function spaces for  $w$  and  $\theta$  are used. For the finite element method, the energy expression is expressed as

$$\frac{\Pi^h l_e}{EI} = \frac{1}{2} \sum_e \left( \int_0^1 \frac{d\theta}{d\xi} \frac{d\theta}{d\xi} d\xi + \frac{GA_0 l^2}{EI} \frac{l_e^2}{l^2} \int_0^1 \left( \frac{1}{l^e} \frac{dw}{d\xi} - \theta \right) \left( \frac{1}{l^e} \frac{dw}{d\xi} - \theta \right) d\xi \right) - l_e^2 \sum_e \int_0^1 \frac{wq}{EI} d\xi$$

To keep the energy expression finite as  $t \rightarrow 0$ , there are two alternatives:

$$1) l^e \approx t, 2) \frac{dw}{dx} \equiv \theta. \text{ The first condition requires a fine mesh layout because the element}$$

size should be almost the same as the thickness of beam. The second condition requires the derivative of displacement field have to be exactly the same as the rotation field, which is very difficult to satisfy. For example, both the displacement and the rotation field are interpolated by linear shape functions, ie,  $w = a\xi + b, \theta = c\xi + d$ . The second condition becomes  $a = c\xi + d$  for all  $0 \leq \xi \leq 1$ , which is equivalent to  $c = 0$  and  $a = d$ . Therefore, the rotation field should be constant within an element. This condition can be satisfied only when the rotation field is constant for the entire beam because of the continuity requirement of  $\theta \in C^0$ , which allows only rigid body rotation of the beam, and yields a meaningless solution. **In case you try to analyze beams or plates, do not use linear shape functions, which merely results in meaningless solutions.**

The aforementioned difficulty may be avoided by using higher order shape functions. In case shape functions of the same order for both fields are employed, the highest order term of the rotation field should always vanish, and the function space for the rotation fields is always a subspace of the displacement field. Since, however, the rotation and the displacement field are totally independent fields as shown in the next section, the solution space of the rotation field has to be defined independently, and thus the aforementioned function space constraint yields sub-optimal convergence and unfavorable results. **Be always very careful when you use  $C^1$ -formulation for the analysis of beams or plates.**

### 11.3. Timoshenko Beam

- **Governing Equation**

$$EI \frac{d^2\theta}{dx^2} + GA_0 \left( \frac{dw}{dx} - \theta \right) = 0 \quad , \quad GA_0 \left( \frac{d^2w}{dx^2} - \frac{d\theta}{dx} \right) = -p$$

- **Weak Form**

$$\int_0^l \delta\theta \left( EI \frac{d^2\theta}{dx^2} + GA_0 \left( \frac{dw}{dx} - \theta \right) \right) dx + \int_0^l \delta w \left( GA_0 \left( \frac{d^2w}{dx^2} - \frac{d\theta}{dx} \right) + p \right) dx = 0 \quad \forall \delta\theta \in \mathcal{V}_\theta \quad \& \quad \forall \delta w \in \mathcal{V}_w$$

$$\int_0^l \delta\theta \left( EI \frac{d^2\theta}{dx^2} + GA_0 \left( \frac{dw}{dx} - \theta \right) \right) dx = \delta\theta EI \frac{d\theta}{dx} \Big|_0^l - \int_0^l \frac{d\delta\theta}{dx} EI \frac{d\theta}{dx} dx + \int_0^l \delta\theta GA_0 \left( \frac{dw}{dx} - \theta \right) dx = 0$$

$$\int_0^l \delta w \left( GA_0 \left( \frac{d^2w}{dx^2} - \frac{d\theta}{dx} \right) + p \right) dx = \delta w GA_0 \left( \frac{dw}{dx} - \theta \right) \Big|_0^l - \int_0^l \frac{d\delta w}{dx} GA_0 \left( \frac{dw}{dx} - \theta \right) dx + \int_0^l \delta w p dx = 0$$

$$\int_0^l \frac{d\delta\theta}{dx} EI \frac{d\theta}{dx} dx + \int_0^l \left( \frac{d\delta w}{dx} - \delta\theta \right) GA_0 \left( \frac{dw}{dx} - \theta \right) dx = \delta\theta EI \frac{d\theta}{dx} \Big|_0^l + \delta w GA_0 \left( \frac{dw}{dx} - \theta \right) \Big|_0^l + \int_0^l \delta w p dx$$

$$\forall \delta\theta \in \mathcal{V}_\theta \quad \& \quad \forall \delta w \in \mathcal{V}_w$$

By assuming homogeneous boundary conditions,

$$\int_0^l \frac{d\delta\theta}{dx} EI \frac{d\theta}{dx} dx + \int_0^l \left( \frac{d\delta w}{dx} - \delta\theta \right) GA_0 \left( \frac{dw}{dx} - \theta \right) dx = \int_0^l \delta w p dx \quad \forall \delta\theta \in \mathcal{V}_\theta \quad \& \quad \forall \delta w \in \mathcal{V}_w$$

- **Boundary Conditions**

$$\theta = 0 \quad \text{or} \quad EI \frac{d\theta}{dx} = 0 \quad \text{or} \quad w = 0 \quad \text{or} \quad GA_0 \left( \frac{dw}{dx} - \theta \right) = 0$$

- **Elimination of the displacement – Beginning of Nightmare**

Differentiation of the first equation and substitution of the second equation into the first equation

$$EI \frac{d^3\theta}{dx^3} + p = 0 \quad (\text{Oh, My God !!!})$$

Unfortunately, we have an odd order differential equation, which does not have the minimum characteristics, and thus is very difficult to solve. At this point, we have to consider the Petrov-Galerkin method seriously !!!

This page is intentionally left blank.

# Chapter 12

## Mixed Formulation



- **What is the mixed formulation??? - Definition**

Stress or strain fields are treated and interpolated independently!!!

- **Governing Equations and Boundary Conditions**

$$\text{Equilibrium Equation} \quad : \quad \nabla \cdot \boldsymbol{\sigma} + \mathbf{b} = 0 \quad \text{in } V$$

$$\text{Constitutive Law} \quad : \quad \boldsymbol{\sigma} = \mathbf{D} : \boldsymbol{\varepsilon} \quad \text{in } V$$

$$\text{Strain-Displacement Relationship} \quad : \quad \boldsymbol{\varepsilon} = \frac{1}{2}(\nabla \mathbf{u} + (\nabla \mathbf{u})^T) \quad \text{in } V$$

$$\text{Displacement Boundary condition} \quad : \quad \mathbf{u} - \bar{\mathbf{u}} = 0 \quad \text{on } S_u$$

$$\text{Traction Boundary Condition} \quad : \quad \mathbf{T} - \bar{\mathbf{T}} = 0 \quad \text{on } S_t$$

$$\text{Cauchy's Relation on the Boundary} \quad : \quad \mathbf{T} = \boldsymbol{\sigma} \cdot \mathbf{n} \quad \text{on } S$$

- **Weak statement.**

$$\int_V \hat{u}_i (\sigma_{ij,j} + b_i) dV + \int_V \hat{\varepsilon}_{ij} (\varepsilon_{ij} - \frac{1}{2}(u_{i,j} + u_{j,i})) dV - \int_{S_t} \hat{u}_i (T_i - \bar{T}_i) dS = 0 \quad \forall \hat{u}_i \in \mathcal{V}_u \quad \hat{\varepsilon}_i \in \mathcal{V}_\varepsilon$$

$$\int_V \hat{u}_i (\sigma_{ij,j} + b_i) dV + \int_V \hat{\varepsilon}_{ij} D_{ijkl} (\varepsilon_{kl} - \frac{1}{2}(u_{k,l} + u_{l,k})) dV - \int_{S_t} \hat{u}_i (T_i - \bar{T}_i) dS = 0 \quad \forall \hat{u}_i \in \mathcal{V}_u \quad \hat{\varepsilon}_i \in \mathcal{V}_\varepsilon$$

$$\int_V \frac{\partial \hat{u}_i}{\partial x_j} \sigma_{ij} dV - \int_V \hat{u}_i b_i dV - \int_{S_t} \hat{u}_i \bar{T}_i dS + \int_V \hat{\varepsilon}_{ij} D_{ijkl} (\varepsilon_{kl} - \frac{1}{2}(u_{k,l} + u_{l,k})) dV = 0 \quad \forall \hat{u}_i \in \mathcal{V}_u \quad \hat{\varepsilon}_i \in \mathcal{V}_\varepsilon$$

$$\int_V \frac{\partial \hat{u}_i}{\partial x_j} D_{ijkl} \varepsilon_{kl} dV - \int_V \hat{u}_i b_i dV - \int_{S_t} \hat{u}_i \bar{T}_i dS + \int_V \hat{\varepsilon}_{ij} D_{ijkl} (\varepsilon_{kl} - \frac{1}{2}(u_{k,l} + u_{l,k})) dV = 0 \quad \forall \hat{u}_i \in \mathcal{V}_u \quad \hat{\varepsilon}_i \in \mathcal{V}_\varepsilon$$

- **Interpolations**

$$\mathbf{u}^e = \mathbf{N}^e \mathbf{U}^e \quad , \quad \boldsymbol{\varepsilon}^e = \mathbf{B}^e \mathbf{U}^e$$

- **Finite element discretization**

$$\sum_e (\hat{\mathbf{U}}^e)^T \left( \int_{V^e} \mathbf{B}^T \mathbf{D} \mathbf{N} dV \right) \mathbf{U}^e - \int_{V^e} \mathbf{N}^T \mathbf{b} dV - \int_{\Gamma_t} \mathbf{N}^T \bar{\mathbf{T}} d\Gamma +$$

$$\sum_e (\hat{\mathbf{E}}^e)^T \left( \int_{V^e} \mathbf{N}^T \mathbf{D} \mathbf{N} dV \right) \mathbf{U}^e - \int_{V^e} \mathbf{N}^T \mathbf{D} \mathbf{B} dV \mathbf{U}^e = 0 \quad \text{for all admissible } \hat{\mathbf{U}}^e \text{ and } \hat{\mathbf{E}}^e$$

$$\mathbf{Q}^T \mathbf{E} = \mathbf{F} \quad , \quad \mathbf{M} \mathbf{E} - \mathbf{Q} \mathbf{U} = 0 \quad \rightarrow \quad \begin{bmatrix} \mathbf{0} & -\mathbf{Q}^T \\ -\mathbf{Q} & \mathbf{M} \end{bmatrix} \begin{bmatrix} \mathbf{U} \\ \mathbf{E} \end{bmatrix} = \begin{bmatrix} -\mathbf{F} \\ \mathbf{0} \end{bmatrix} \rightarrow \mathbf{Q}^T \mathbf{M}^{-1} \mathbf{Q} \mathbf{U} = \mathbf{F}$$



- **Important Question**

What are the admissible function spaces for the displacement field and the strain field?? Can we choose the interpolation shape functions for the displacement and the strain independently ?? **Unfortunately, the answer is “No”.** In case we choose the function spaces arbitrarily, the solutions of the mixed formulation become very unstable, which is caused by so called “function space interlocking”. The Babuzuka-Brezzi condition (BB condition) states the required relationship between the individual function spaces. This issue is out of scope for this class.

**Please be very careful when you use the FEM based on the mixed formulation!!!**

- **Possible choices of function spaces**

1.  $\hat{u}_i \in H^1$  ,  $\hat{\varepsilon}_i \in H^1$
2.  $\hat{u}_i \in H^1$  ,  $\hat{\varepsilon}_i \in L_2$
3.  $\hat{u}_i \in L_2$  ,  $\hat{\varepsilon}_i \in L_2$

**Which one do you like? Can you give a proper explanation for your choice?**